**User's
Manual**

GREEN Series Communication Functions



IM 05G01B02-01E

Introduction

This user's manual describes the communication functions of the GREEN Series of controllers and provides information on how to create communication programs.

The GREEN Series use the following internal registers and relays:

- 1) D registers
- 2) B registers <UP750 and UP550 only>
- 3) I relays

The GREEN Series controllers can communicate with a higher-level device via these internal registers.

You are required to understand the communication specifications of higher-level devices, as a background knowledge, in regard to their communication hardware, language used for creating communication programs, and so on.

* Higher-level devices: PCs, PLCs (sequencers), graphic panels, and others

■ Intended Readers

This manual is intended for people familiar with the functions of the GREEN Series controllers such as control engineers and personnel in charge of the maintenance of instrumentation and control equipment.

■ Related Documents

The following user's manuals all relate to the communication functions of the GREEN Series. Read them as necessary. The codes enclosed in parentheses are the document numbers.

- ***UT350/UT320 User's Manual***
(IM 05D01D02-01E to 03E)
Explains the basic operation of the UT350/UT320 controller.
- ***UT351/UT321 User's Manual***
(IM 05D01D12-01E to 04E)
Explains the basic operation of the UT351/UT321 controller.
- ***UT450/UT420 User's Manual***
(IM 05D01C12-01E to 04E)
Explains the basic operation of the UT450/UT420 controller.
- ***UT550/UT520 User's Manual for Single-loop Control***
(IM 05D01C02-01E to 05E)
Explains the basic operation of the UT550/UT520 controller.
- ***UT551 with Embedded Ethernet User's Manual for Single-loop Control***
(IM 05D01C03-01E to 06E)
Explains the basic operation of the UT551 controller.

- ***UT551 User's Manual for Single-loop Control (IM 05D01C04-01E to 06E)***
Explains the basic operation of the UT551 controller.
- ***UT750 User's Manual for Single-loop Control (IM 05D01B02-01E to 05E)***
Explains the basic operation of the UT750 controller.
- ***UP350 User's Manual (IM 05E01D02-01E to 04E)***
Explains the basic operation of the UP350 controller.
- ***UP351 User's Manual (IM 05E01D12-01E to 05E)***
Explains the basic operation of the UP351 controller.
- ***UP550 User's Manual for Single-loop Control (IM 05E01C02-01E to 07E)***
Explains the basic operation of the UP550 controller.
- ***UP750 User's Manual for Single-loop Control (IM 05E01B02-01E to 07E)***
Explains the basic operation of the UP750 controller.
- ***UM350/UM330 User's Manual (IM 05F01D02-01E to 03E)***
Explains the basic operation of the UM350/UM330 indicator.
- ***UM351/UM331 User's Manual (IM 05F01D12-01E to 04E)***
Explains the basic operation of the UM351/UM331 indicator.
- ***GREEN Series User's Manual - Detailed Instructions - (IM 05J01B02-01E)***
Explains the functions of the GREEN Series controllers in detail.
- ***GREEN Series Communication Function (IM 05G01B02-01E)***
Provides detailed information about the GREEN Series controller's communication protocol.
- ***GREEN Series Communication Reference (IM 05G01B02-02E)***
Provides detailed information about the GREEN Series controller's internal registers that can be accessed by communication.

- ***LL100 PC-based Parameters Setting Tool***
(IM 05G01B12-01E)

A user's manual for setting the parameters of the GREEN Series controllers from a personal computer.
- ***LL200 PC-based Custom Computation Building Tool***
(IM 05G01B22-01E)

A user's manual for creating GREEN Series custom computations on a personal computer.
- ***LL200 PC-based Custom Computation Building Tool User's Reference***
(for UT750: IM 05G01B22-02E)
(for UP750: IM 05G01B22-03E)

A user's manual that describes the functions needed to create GREEN Series custom computations. Refer to this manual if you are not familiar with the types of functions available or how these functions work.
- ***Ethernet Communication Functions***
(IM 05G01B52-01E)

Provides information about Ethernet communication.

Documentation Conventions

■ Symbols



WARNING

Indicates that operating the hardware or software in this manner may damage it or lead to system failure.



NOTE

Draws attention to information that is essential for understanding the operation and/or features of the product.

TIP

Gives additional information to complement the present topic.

See Also

Gives reference locations for further information on the topic.

■ Description of Displays

- (1) Some of the representations of product displays shown in this manual may be exaggerated, simplified, or partially omitted for reasons of convenience when explaining them.
- (2) Figures and illustrations representing the controller's displays may differ from the real displays in regard to the position and/or indicated characters (upper-case or lower-case, for example), to the extent that they do not impair a correct understanding of the functions and the proper operation and monitoring of the system.

Notices

■ Regarding This User's Manual

- (1) This manual should be passed on to the end user. Keep at least one extra copy of the manual in a safe place.
- (2) Read this manual carefully to gain a thorough understanding of how to operate this product before you start using it.
- (3) This manual is intended to describe the functions of this product. Yokogawa Electric Corporation (hereinafter simply referred to as Yokogawa Electric) does not guarantee that these functions are suited to the particular purpose of the user.
- (4) Under absolutely no circumstance may the contents of this manual, in part or in whole, be transcribed or copied without permission.
- (5) The contents of this manual are subject to change without prior notice.
- (6) Every effort has been made to ensure accuracy in the preparation of this manual. Should any errors or omissions come to your attention however, please contact your nearest Yokogawa representative or our sales office.

■ Regarding Protection, Safety, and Prohibition Against Unauthorized Modification

- (1) In order to protect the product and the system controlled by it against damage and ensure its safe use, make certain that all of the instructions and precautions relating to safety contained in this document are strictly adhered to. Yokogawa Electric does not guarantee safety if products are not handled according to these instructions.
- (2) Modification of the product is strictly prohibited.
- (3) Reverse engineering such as the disassembly or decompilation of software is strictly prohibited.

■ Force Majeure

- (1) Yokogawa Electric does not make any warranties regarding the product except those mentioned in the WARRANTY that is provided separately.
- (2) Yokogawa Electric assumes no liability to any party for any loss or damage, direct or indirect, caused by the use or any unpredictable defect of the product.
- (3) Be sure to use the spare parts approved by Yokogawa Electric when replacing parts or consumables.
- (4) Modification of the product is strictly prohibited.
- (5) Use this software with one specified computer only. You must purchase another copy of the software for use on each additional computer.
- (6) Copying this software for purposes other than backup is strictly prohibited.
- (7) Store the floppy disk(s) (original medium or media) containing this software in a secure place.
- (8) Reverse engineering such as the disassembly or decompilation of software is strictly prohibited.
- (9) No portion of the software supplied by Yokogawa Electric may be transferred, exchanged, leased or sublet for use by any third party without the prior permission of Yokogawa Electric.

■ Trademarks

Windows98/2000/XP and Windows NT 4.0 are registered trademarks of Microsoft Corporation, USA.

“Ethernet” is registered trademark of XEROX Corporation.

GREEN Series Communication Functions

IM 05G01B02-01E 6th Edition

CONTENTS

- Introduction i
- Documentation Conventionsiv
- Notices v
- 1. Communications Overview 1-1
 - 1.1 Interface Specifications 1-2
- 2. Setup 2-1
 - 2.1 Setup Procedure 2-1
 - 2.2 Wiring for Communication 2-2
 - 2.2.1 Wiring to a Personal Computer 2-2
 - 2.2.2 Wiring to a PLC (Sequencer) or Graphic Panel 2-3
 - 2.2.3 Wiring for Coordinated Operation 2-4
 - 2.2.4 Wiring for Contact I/O Expansion 2-5
 - 2.3 Notes on Setting Communication Parameters 2-6
 - 2.3.1 Procedure to Set Communication Parameters 2-6
 - 2.3.2 Description of Communication Parameters 2-7
- 3. PC Link Communication 3-1
 - 3.1 Overview 3-1
 - 3.1.1 Configuration of Commands 3-2
 - 3.1.2 Configuration of Response 3-4
 - 3.2 Communication with Higher-level Device 3-5
 - 3.2.1 List of Commands 3-6
 - 3.2.2 Specifying Broadcast 3-7
 - 3.2.3 Commands 3-8
 - BRD Reads I relays on a bit-by-bit basis. 3-8
 - BWR Writes data into I relays on a bit-by-bit basis. 3-9
 - BRR Reads I relays on a bit-by-bit basis in a random order. 3-10
 - BRW Writes data into I relays on a bit-by-bit basis in a random order. 3-11
 - BRS Specifies I relays to be monitored on a bit-by-bit basis. 3-12
 - BRM Monitors I relays on a bit-by-bit basis. 3-13
 - WRD Reads D registers and I relays on a word-by-word basis. 3-14
 - WWR Writes data into D registers and I relays on a word-by-word basis. ... 3-15
 - WRR Reads D registers and I relays on a word-by-word basis in random order. 3-16

- WRW Writes data into D registers and I relays on a word-by-word basis in random order. 3-17
- WRS Specifies the D registers and I relays to be monitored on a word-by-word basis. 3-18
- WRM Monitors the D register and I relays on a word-by-word basis. ... 3-19
- INF Reads the model, version, and revision information. 3-20
- UMD Sets the UT/UP mode (control function). 3-22
- USM Changes the PV input sampling period. 3-22
- 3.2.4 Response Error Codes 3-23
- 3.3 Example of BASIC Program for Send and Receive 3-24
- 4. Ladder Communication 4-1
 - 4.1 Overview 4-1
 - 4.1.1 Configuration of Commands 4-2
 - 4.1.2 Configuration of Response 4-3
 - 4.2 Communication with PLC 4-4
 - 4.2.1 Reading Data 4-5
 - 4.2.2 Writing Data 4-6
 - 4.2.3 Response Error Codes 4-7
- 5. MODBUS Communication 5-1
 - 5.1 Overview 5-1
 - 5.1.1 Configuration of Messages 5-2
 - 5.2 Communication with Higher-level Device 5-3
 - 5.2.1 List of Function Codes 5-4
 - 5.2.2 Specifying Broadcast 5-4
 - 5.2.3 Function Codes 5-5
 - 5.2.4 Response Error Codes 5-9
- 6. Coordinated Operation 6-1
 - 6.1 Overview 6-1
 - 6.2 Starting Coordinated Operation 6-3
- 7. Contact I/O Expansion 7-1
 - 7.1 Overview 7-1
 - 7.2 Setting Up Contact I/O Expansion 7-1
- Revision Information i

1. Communications Overview

The GREEN Series controllers have an RS-485 serial communication interface, through which data exchange is performed with a device such as a personal computer, PLC (sequencer), and graphic panel.

The following five communication protocols are supported.

Table 1.1 Communication Protocols

Communication protocol	Protocol specification	Applicable models of GREEN Series
PC link communication	Without sum check	All models
	With sum check	
Ladder communication	Handshaking	
MODBUS communication	RTU mode	
	ASCII mode	
Coordinated operation	Specific to GREEN Series	All models except for UM350/UM330, UM351/UM331
Contact I/O expansion	μ-Bus (specific to μFA20)	UT750, UP750

Table 1.2 Connectable Devices

Communication protocol	Connectable device	Requirements
PC link communication	Personal computer	RS-232C/RS-485 converter
	Graphic panel	-
	PLC (sequencer)	With serial communication module
Ladder communication	PLC (sequencer)	With ladder communication module
MODBUS communication	Personal computer Graphic panel PLC (sequencer)	With DDE server or other
Coordinated operation	GREEN Series controllers (excluding UM350/UM330, UM351/UM331)	Master only: UP750/UP550/UP350/UP351 Master/slave: UT750/UT550/UT520/UT551/UT450/UT420/UT350/UT320/UT351/UT321
Contact I/O expansion	μFA20 expansion modules (μFA20-related products)	UT750/UP750

1.1 Interface Specifications

Table 1.3 RS-485 Interface

Interface	Communication system	Communication rate	Other specifications	Protocols available
Standard RS-485	4-wire, half-duplex	600, 1200 2400, 4800	Asynchronous (start-stop) Handshaking Maximum communication distance: 1200 m	PC link communication Ladder communication MODBUS communication Coordinated operation
	2-wire, half-duplex	9600bps		
High-speed RS-485	2-wire, half-duplex	600, 1200 2400, 4800 9600, 19.2k 38.4kbps	Maximum number of connectable devices: 31 Start bit: 1 Data length: 8 or 7 bits Parity: No parity, even, odd Stop bit: 1 or 2	PC link communication Ladder communication MODBUS communication Coordinated operation Contact I/O expansion

Table 1.4 Contact I/O Expansion Interface

Interface	Specification	Other specification
Contact I/O expansion	Input: 16 points can be added at maximum. Output: 16 points can be added at maximum. (When two μ FA20 expansion modules are connected)	Maximum communication distance: 15 m

2. Setup

This chapter describes the procedure to set up the communication functions and also refers to some notes on wiring and communication parameters.

2.1 Setup Procedure

Set up the communication functions of the GREEN Series as follows:

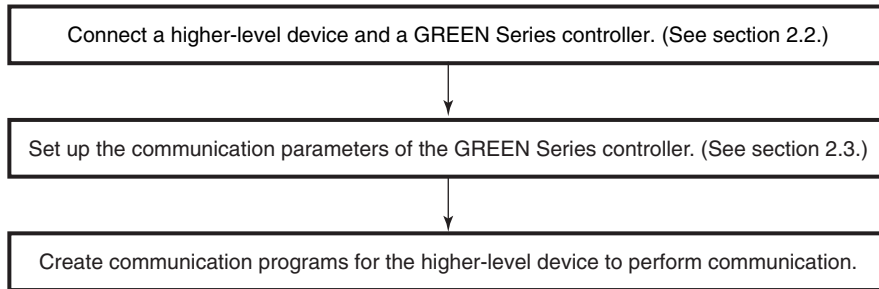

- * Create communication programs referring to the documentation of each higher-level device.
- * In this manual, "higher-level devices" generically denotes PCs, PLCs (sequencers), and graphic panels.

2.2 Wiring for Communication

Connect the GREEN Series controller and the higher-level device for communication. The wiring procedures and precautionary notes are as follows.

NOTE

To avoid an electric shock, be sure to turn off the power supply source to the equipment involved before you start wiring.

Use crimp terminals at cable ends.

Before you start wiring, read the user’s manual of each device.

2.2.1 Wiring to a Personal Computer

● 4-wire connection

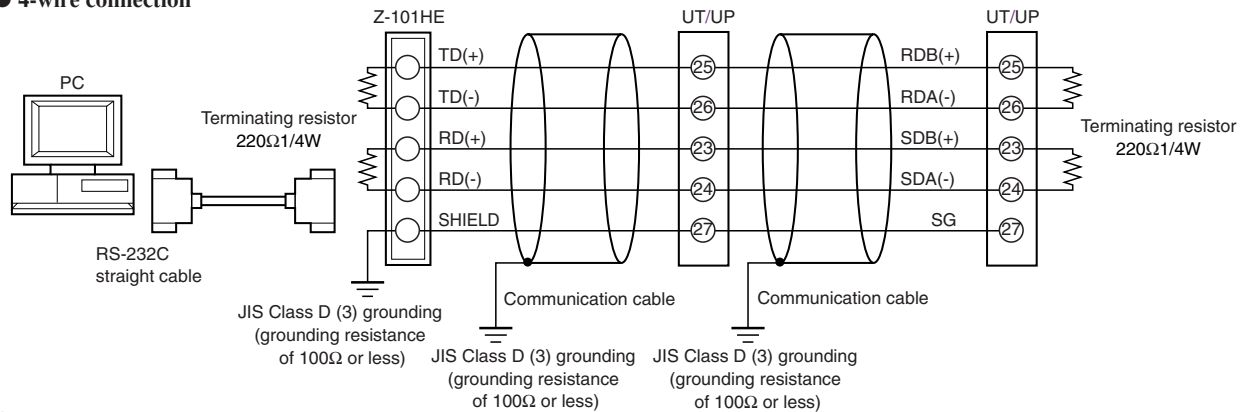

● 2-wire connection

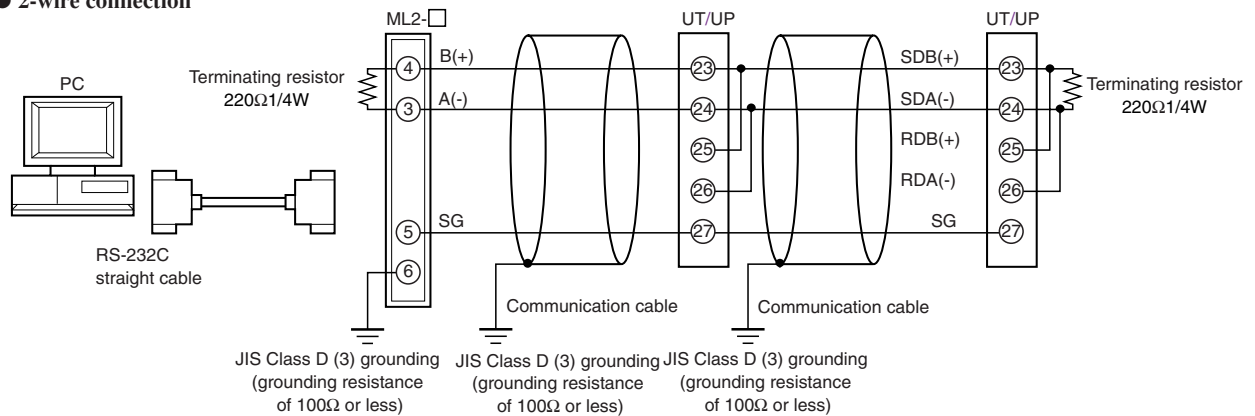

Note: Z-101HE and ML2 are the converters of Sharp Corporation and Yokogawa Electric Corporation, respectively. You can also use other RS-232C/RS-485 converters. Before you use another converter, check its electrical specifications.
* For the wiring via the high-speed RS-485 interface of UT750/UP750, see subsection 2.2.2.

2.2.2 Wiring to a PLC (Sequencer) or Graphic Panel

Since general PLCs (sequencers) and graphic panels have an RS-485 interface, they can be directly connected to a GREEN Series controller. If your PLC (sequencer) or graphic panel has an RS-232C interface, see subsection 2.2.1.

● **4-wire connection**

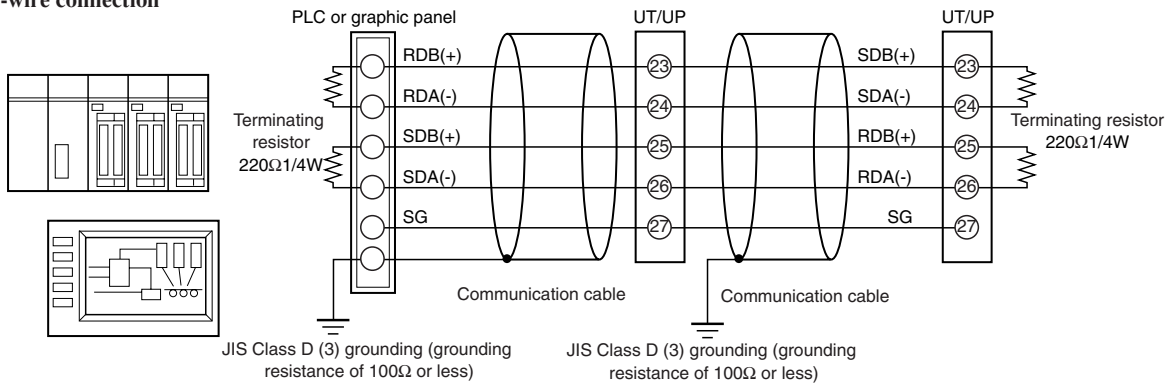

● **2-wire connection**

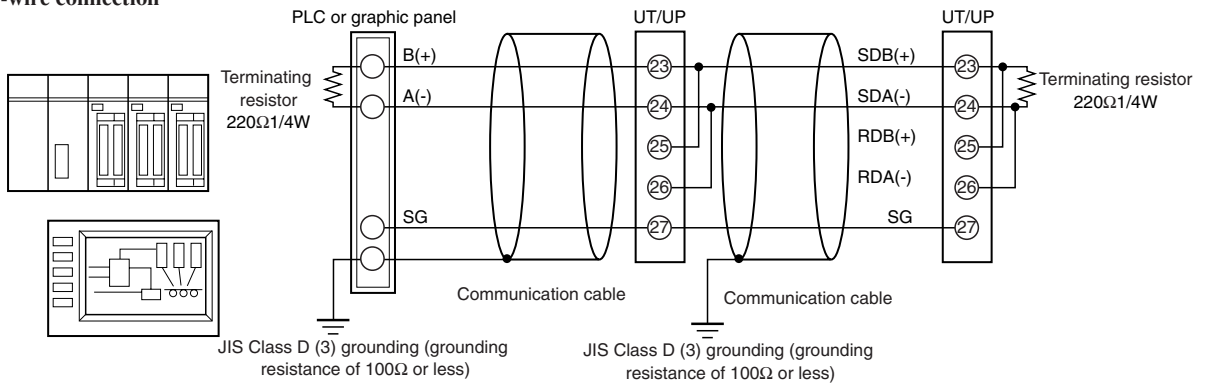

Wiring via the UT750/UP750's high-speed RS-485 interface is common with a PC, PLC (sequencer), and graphic panel.

● **High-speed RS-485 interface (2-wire) connection (UT750/UP750 only)**

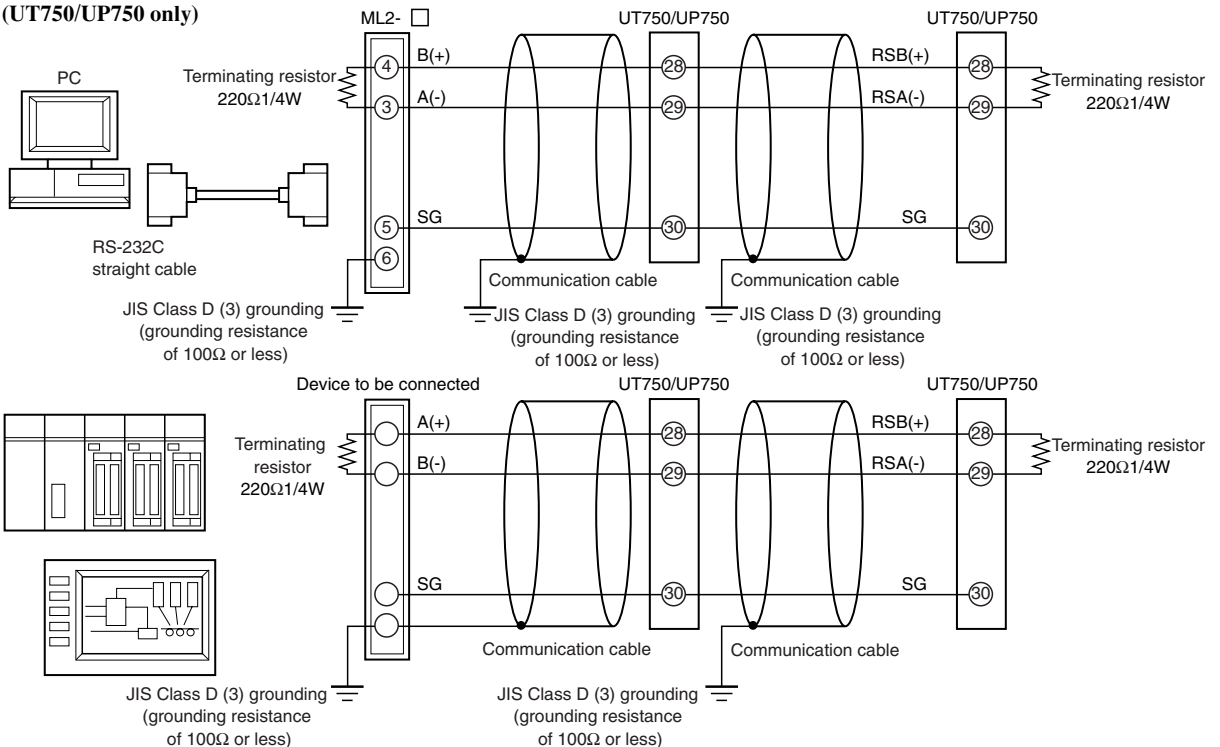

2.2.3 Wiring for Coordinated Operation

Coordinated operation can be configured by connecting a GREEN Series controller as both a master and slave. There are some restrictions regarding the controller model (whether the model can be a master or slave) when setting the protocol selection parameter for coordinated operation. (See section 2.3.)

● **Standard RS-485 interface connection**

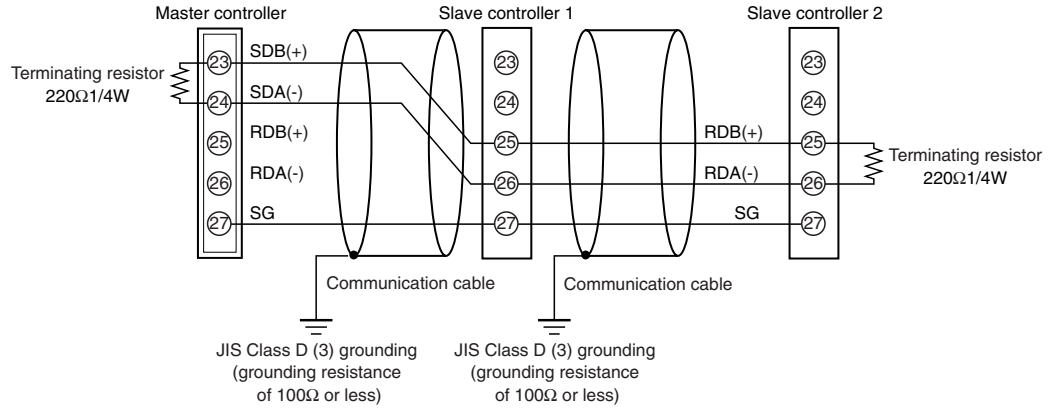

● **High-speed RS-485 interface connection (UT750/UP750 only)**

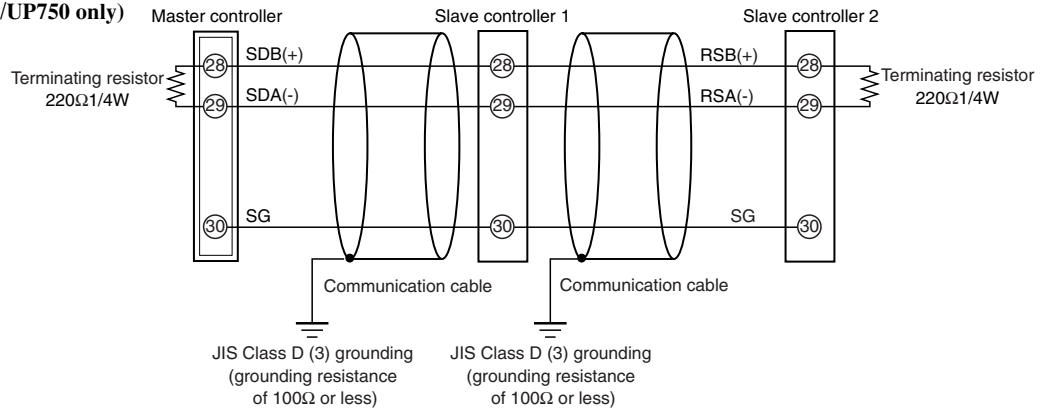

2.2.4 Wiring for Contact I/O Expansion

Expansion modules of μ FA20 Small Programmable Controller can be connected to a master device of UT750/UP750.

Table 2.2.4 μ FA20 Expansion Modules

Model	Input specification	Output specification	Power supply
P2ER1-20J	12 points (24VDC, 5mA)	8 points (Relay contacts)	100 to 240 V AC
P2ET1-20J	12 points (24VDC, 5mA)	8 points (Transistor contacts)	
P2ER6-20J	12 points (24VDC, 5mA)	8 points (Relay contacts)	24 V DC
P2ET6-20J	12 points (24VDC, 5mA)	8 points (Transistor contacts)	

● **High-speed RS-485 interface (2-wire) connection (UT750/UP750 only)**

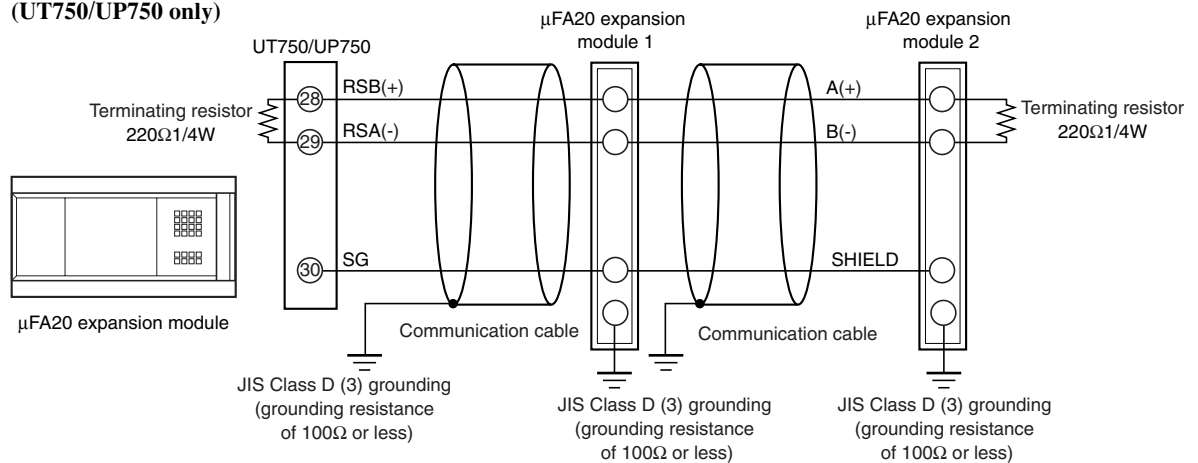

NOTE

Do not share the grounding wire with another controller. Doing so may result in a failure of the controller.

Use crimp terminals at the cable ends.

2.3 Notes on Setting Communication Parameters

This section describes the parameters that set up the communication functions and their setting ranges.



NOTE

The communication specifications of both the GREEN Series controller and the higher-level device must be the same. Check the communication specifications of the higher-level device first, then set up the communication parameters of the GREEN Series controller.

2.3.1 Procedure to Set Communication Parameters

For the operation procedure, see the User’s Manual of each GREEN Series controller.

The GREEN Series are shipped from the factory with the following communication specifications.

Table 2.3.1 Protocol-by-Protocol Default Parameter Settings

Communication protocol	PSL	BPS	PRI	STP	DLN
PC link communication (without sum check)	0	9600	EVEN	1	8
PC link communication (with sum check)	1	9600	EVEN	1	8
Ladder communication	2	9600	EVEN	1	⑧
MODBUS communication (ASCII mode)	7	9600	EVEN	1	⑦
MODBUS communication (RTU mode)	8	9600	EVEN	1	⑧
Coordinated operation	3, 4, 9, 10, 11	9600	EVEN	1	8
Contact I/O expansion	5, 6	9600	EVEN	1	8

Note: Circled numbers denote fixed values (i.e., the parameters can neither be shown nor changed).

2.3.2 Description of Communication Parameters

Table 2.3.2 Communication Parameters of GREEN Series

Parameter name	Parameter code	Setting range		Default
Protocol selection ^{*1}	PSL (PSL1)	PC link communication	0: Without sum check 1: With sum check	0
		Ladder communication	2: Ladder communication	
		Coordinated operation	3: Master 4: Slave 9: Master (2-loop mode) 10: Slave (Loop-1 mode) 11: Slave (Loop-2 mode)	
		MODBUS communication	7: ASCII mode 8: RTU mode	
	PSL2	PC link communication	0: Without sum check 1: With sum check	
		Ladder communication	2: Ladder communication	
		Coordinated operation	3: Master 4: Slave 9: Master (2-loop mode) 10: Slave (Loop-1 mode) 11: Slave (Loop-2 mode)	
		Contact I/O expansion	5: Add one module 6: Add two modules	
Address	ADR n	1 to 99		1
Baut rate ^{*1}	BPS (BPS1)	600, 1200, 2400, 4800, 9600 (bps)		9600
	BPS2	600, 1200, 2400, 4800, 9600, 19.6k, 38.4k (bps)		9600
Parity	PRI n	NONE (no parity), EVEN, ODD		EVEN
Stop bit	STP n	1, 2 (bit)		1
Data length	DLN n	7, 8 (bit) ^{*2}		8
Minimum response time	RP.T n	0 to 10 (×10 ms)		0

*1: UT750 and UP750 have two sets of parameters (n = 1, 2) for their two communication ports. Note that among the parameters, protocol selection (PSL1 and PSL2) and baud rate (BPS1 and BPS2) have different setting ranges between the two ports.

*2: Data length is fixed at 8 bits for ladder communication, and when MODBUS communication is selected, 7 bits for ASCII mode and 8 bits for RTU mode.

1) Protocol selection (PSLn)

Set the same communication protocol as that of the higher-level device to be connected to. The GREEN Series supports PC link, ladder, and MODBUS communication protocols and, in addition, coordinated operation and contact I/O expansion protocols, which are specific to GREEN Series.

- Restrictions of coordinated operation

UM350/UM330/UM351/UM331 cannot be involved in coordinated operation.

3: Master Applicable to any UT and UP controller.
(For UT750 and UP750, can be assigned to PSL2)

4: Slave Applicable to UT750, UT550/UT520, UT551, UT450/UT420, UT350/UT320, and UT351/UT321
(For UT750, can be assigned to PSL2)

9: Master (2-loop mode) Applicable to UT750, UP750, and UP550
(For UT750 and UP750, can be assigned to PSL2)

10: Slave (Loop-1 mode) Applicable to UT750, UT550/UT520, UT551, UT450/UT420, UT350/UT320, and UT351/UT321
(For UT750, can be assigned to PSL2)

11: Slave (Loop-2 mode) Applicable to UT750, UT550/UT520, UT551, UT450/UT420, UT350/UT320, and UT351/UT321
(For UT750, can be assigned to PSL2)

- Restrictions of contact I/O expansion

I/O expansion can be assigned only to PSL2 of UT750 and UP750.

2) Baud rate (BPSn)

Set the same baud rate as that of the higher-level device to be connected. (Otherwise, proper communication cannot be achieved.) The unit of baud rate is bps (bits per second).

3) Address number (ADRn)

Set the address number of the GREEN Series controller to one that is not being used by another controller. An address number of 1 to 99 can be assigned in any order. Note that the number of GREEN Series controllers that can be connected to a single communication port is limited to 31.

Example of connecting four GREEN Series controllers to a higher-level device with address numbers of 1, 50, 10, and 20:

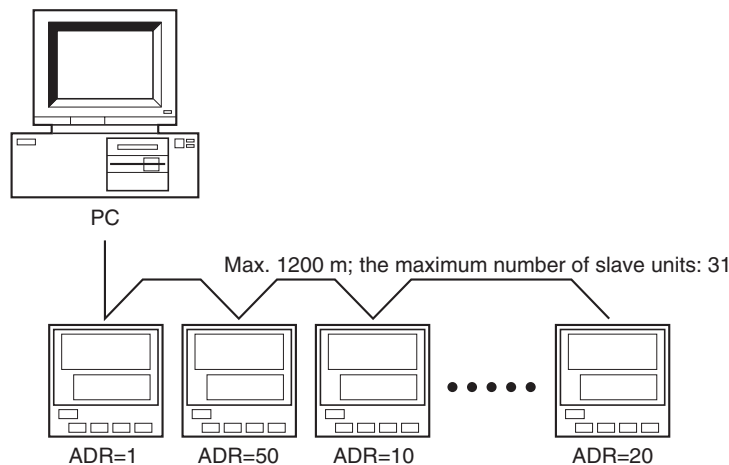

4) Parity (PRIn)

Set the handling of parity to be carried out when data is sent or received. Set the same parity state as that of the higher-level device to be connected.

5) Stop bit (STPn)

Set the same stop bit as that of the higher-level device to be connected.

6) Data length (DLNn)

Set the same data length as that of the higher-level device to be connected. (When ladder communication or MODBUS communication is selected, the data length is fixed.)

7) Minimum response time (RP.Tn)

Set the time taken to respond to the higher-level device after the GREEN Series controller receives transmission data from it. The unit is 10 ms. The response time will be “communication processing time + the set value of RP.T X 10” milliseconds.

Blank Page

3. PC Link Communication

3.1 Overview

PC link communication protocol is one of the protocols used to communicate with devices such as PCs, PLCs (sequencers), and graphic panels. Via this communication protocol, these devices can exchange data with a GREEN Series controller by reading/writing the controller's internal registers (D/B registers and I relays).

Hereafter, PCs, PLCs (sequencers), and graphic panels shall be referred to as "higher-level devices."



See Also

GREEN Series Communication Reference (IM 05G01B02-02E) for information about internal registers.

In PC link communication, a higher-level device identifies each GREEN Series controller with a communication address, which ranges from 1 to 99. However, broadcasting, which requires no address number, is possible with some of the commands. For more information, see subsection 3.2.2.

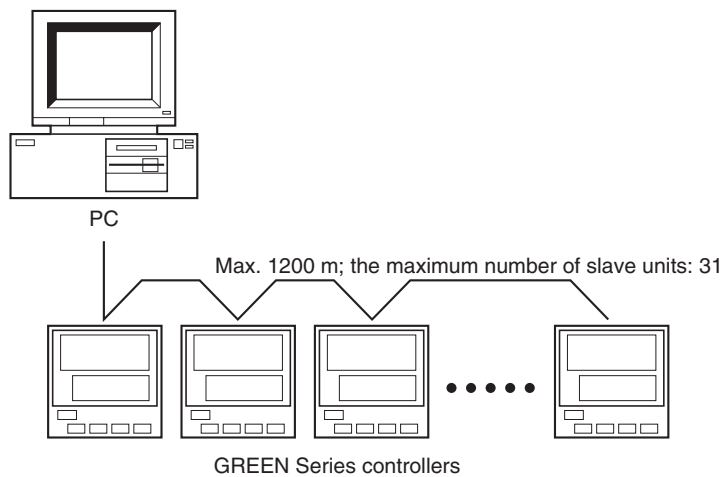

Figure 3.1 Connection of PC Link Communication

The next section will discuss the configuration of commands and responses.

3.1.1 Configuration of Commands

Commands sent from a higher-level device to a GREEN Series controller consist of the following elements.

Number of bytes	1	2	2	1	3	Variable length	2	1	1
Element	STX	Address number (ADR)	CPU number 01	Time to wait for response 0	Command	Data corresponding to command	Checksum	ETX	CR
	(1)	(2)	(3)	(4)	(5)	(6)	(7)	(8)	(9)

(1) STX (Start of Text)

This control code indicates the start of a command. The character code is CHR\$(2).

(2) Address Number (01 to 99)

Address numbers are used by a higher-level device to identify which GREEN Series controller to communicate with. (ID number of the GREEN Series)

(3) CPU Number

This number is fixed to 01.

(4) Time to Wait for Response

This is fixed to 0.

(5) Command (See subsection 3.2.1.)

Specify a command to be issued from the higher-level device.

(6) Data Corresponding to Command

Specify an internal register (D/B register or I relay), number of data items, GREEN Series' parameter values, or others.

(7) Checksum

In PC link communication with sum check, the ASCII codes of the text between STX and the checksum are converted into hexadecimal values and added on a byte basis. Then the lowermost byte of the added results is turned into ASCII code, and its lower byte is used as the checksum.

This 2-byte space is unnecessary for PC link communication without sum check.

(8) ETX (End of Text)

This control code indicates the end of a command string. The character code is CHR\$(3).

(9) CR (Carriage Return)

This control code marks the end of a command. The character code is CHR\$(0D).(5)
The Select Series dialog box (Figure 3.1.2) appears.



NOTE

The control codes STX, ETX, and CR in commands are indispensable. Do not miss any of them when you create a communication program for PC link communication. A communication failure will result if any of them are omitted or if the order is incorrect.

● Data Forms of Commands

The table below shows the data forms of D/B registers and I relays.

Table 3.1 Data Forms

Data type	Data content	Data form
PV high and low limits, target setpoints, and others	Measuring range (EU) data	Numeric data excluding the decimal point
Bias, deviation alarms, and others	Measuring range span (EUS) data	Numeric data excluding the decimal point
Proportional bands, upper and lower limits of output, and others	% data (0.0 to 100.0%)	0 to 1000
Various modes, alarm types, and others	Seconds, absolute values, and data without unit*	Absolute value excluding the decimal point

* Parameter list of GREEN series User's Manual (Reference) for information about data form.

● Command Format for Communication

Example: When setting a target setpoint "50.0" to a GREEN Series controller, the higher-level device sends the value "500" as command data without the decimal point (this is true for both settings 5.00 or 500).

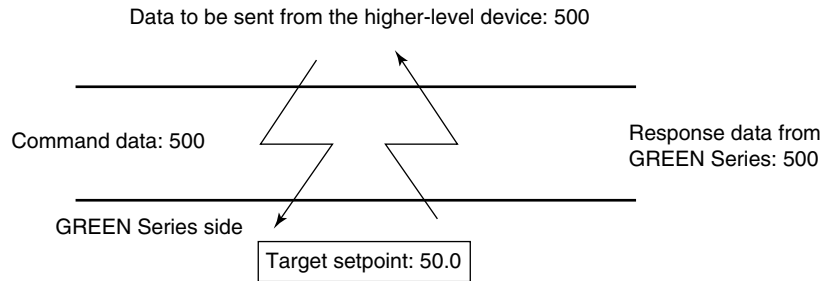

* The position of the decimal point for "500" is determined by the DP (decimal point position) parameter of the GREEN Series.

3.1.2 Configuration of Response

Responses from a GREEN Series controller with respect to a command sent from the higher-level device consist of the elements shown below, which differ depending on the condition of communication - normal or failure.

1) With Normal Communication

When communication is carried out normally, the GREEN Series controller returns the character string "OK" and, in response to read commands, also returns read-out data.

Number of bytes	1	2	2	2	Variable length	2	1	1
Element	STX	Address number (ADR)	CPU number:01	OK	Parameter data	Checksum	ETX	CR

2) In the Event of Failure

If communication is carried out abnormally, the GREEN Series returns the character string "ER" and error codes (EC1 and EC2). (See subsection 3.2.4, Response Error Codes.)

- No response is made in case of an error in address number specification or CPU number specification.
- If a GREEN Series controller cannot receive amQ'TX contained in a command, a response may not be made.

* As a measure against these situations, provide a timeout processing in the communication functions or communication programs of the higher-level device.

Number of bytes	1	2	2	2	2	2	3	2	1	1
Element	STX	Address number (ADR)	CPU number:01	ER	EC1	EC2	Command	Checksum	ETX	CR

3.2 Communication with Higher-level Device

In PC link communication, when specifying D registers/B registers or I relays (internal registers of GREEN Series), you can use the numbers as is. The numbers of these internal registers are in the following format:

- D registers/B registers : D****/B**** (****: numeric value)
- I relays : I**** (****: numeric value)

Higher-level devices to be connected to a GREEN Series controller are those capable of handling the PC link communication protocol.

(1) Connectable graphic panels

Graphic panels that can be connected to a GREEN Series controller are listed below. However, it may be possible to connect graphic panels other than the ones listed below.

Table 3.2 List of Graphic Panels Connectable

Product	Name	Name	Remarks
Pro-face by Digital Electronics Corporation	GP70 series	Graphic control panel	(Note)
	GP-J series	High-speed graphic control panel	
	GP-230 series	Medium-size graphic control panel	
	GP-430 series	Advanced, high-speed graphic control panels	
	GP-530 series		

Note: For more information about Digital’s graphic panels, contact Digital Electronics Corporation.
(Be careful because the display device differs depending on the model.)

(2) Communication with FA-M3 with UT-link module

No ladder communication program is required to communicate with FA-M3 with UT-link module (Yokogawa PLC). The UT-link module’s function offers 3 modes, in which users can exchange data without paying attention to the communication procedure. (For more information, see the user’s manual of UT Link module “IM 34M6H25-01E.”)

- Non-user-specifiable mode: Always reads the predetermined devices* of the GREEN Series controllers (users cannot specify devices).
- Predetermined devices* of UT750/UP750, UT550/UP550/UT520, UT551 and UT450/UT420: D0001 to D0025
- Predetermined devices* of UT350/UP350/UT320, UT351/UP351/UT321, UM350/UM330 and UM351/UM331: D0001 to D0008

(Since these devices* are in the read only area of GREEN Series controllers, they cannot be written to.)

- User-specifiable mode: Always reads/writes the user-specified devices* of the GREEN Series controller.
- Command mode: Accesses the devices* of the GREEN Series only when necessary.

*: “Predetermined device” or “device” here denotes the internal registers of the GREEN Series (D registers and I relays).

3.2.1 List of Commands

The following are the lists of commands available in PC link communication. The details of them are explained in the description of each command.

(1) Bit-basis Access Commands Dedicated to I Relays

Command	Description	Number of bits handled
BRD	Bit-basis read	1 to 256 bits
BWR	Bit-basis write	1 to 256 bits
BRR	Bit-basis, random read	1 to 32 bits
BRW	Bit-basis, random write	1 to 32 bits
BRS	Specifies I relays to be monitored on a bit-by-bit basis.	1 to 32 bits
BRM	Bit-basis monitoring	—

(2) Word-basis Access Commands

Command	Description	Number of words handled
WRD	Word-basis read	1 to 64 words
WWR	Word-basis write	1 to 64 words
WRR	Word-basis, random read	1 to 32 words
WRW	Word-basis, random write	1 to 32 words
WRS	Specifies internal registers to be monitored on a word-by-word basis.	1 to 32 words
WRM	Word-basis monitoring	—

(3) Information Commands

Command	Description	Number of controllers handled
INF	Reads model, version, and revision.	1
UMD	Sets control function (UT/UP mode).*	1
USM	Changes PV input sampling period.*	1

*: Available only for UT750/UP750, UT550/UP550, UT551 and UT520.

3.2.2 Specifying Broadcast

Broadcast addressing allows the corresponding multiple GREEN Series controller to receive the command.

- (1) In the command, specify the broadcast address in Table 3.3 and execute it.
- (2) Broadcast addressing works independently of the communication address of the controller.
- (3) Broadcast addressing is only applicable to write commands.
- (4) No response is returned when broadcast addressing is used.

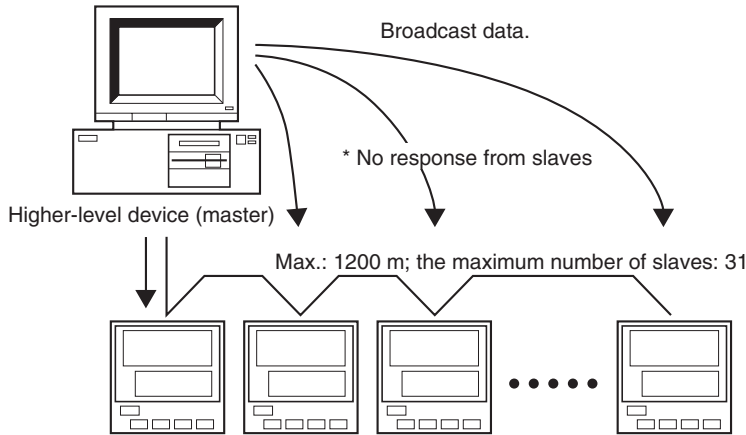

Figure 3.2 Broadcasting

Table 3.3 Address Numbers

Address No.	Corresponding devices
B1	All UT750s
B2	All UP750s
B3	All UT550/UT520, UT551, UT450/UT420s
B4	All UP550s
B5	All UT350/UT320/UT351/UT321s
B6	All UM350/UM330/UM351/UM331s
B7	All UP350/UP351s
BA	All models of GREEN Series
BT	All UT controllers of GREEN Series
BP	All UP controllers of GREEN Series
00	All devices supporting PC link communication
01 to 99	Device with a corresponding address number

3.2.3 Commands

BRD Reads I relays on a bit-by-bit basis.

● **Function**

Reads the ON/OFF statuses of a sequence of contiguous I relays by the specified number of bits, starting at a specified I relay number.

- The number of bits to be read at a time is 1 to 256.
- For the format of response in the event of failure, see subsection 3.1.2.
- The command shown below includes the checksum function. When performing communication without checksum, do not include the 2-byte checksum element in the command.

● **Command/Response (for normal operation)**

Number of Bytes	1	2	2	1	3	5	1	3	2	1	1
Command element	STX	Address number (ADR)	CPU number 01	0	BRD	I relay number	Comma or space	Number of bits (n)	Checksum	ETX	CR

Number of Bytes	1	2	2	2	1	1	1	...	1	2	1	1
Response element	STX	Address number (ADR)	CPU number 01	OK	d1	d2	d3	...	dn	Checksum	ETX	CR

The response is “0” when the status is OFF or “1” when ON.

{

dn: read data of the specified number of bits (n = 1 to 256)

dn = 0 (OFF)

dn = 1 (ON)

}

● **Example**

Reading the status of alarm 1 of the GREEN Series with address number 01

The following command reads the status of alarm 1 (I0097) at address number 01.

[Command]

STX\$+ “01010BRDI0097, 001A0” +ETX\$+CR\$

The following response is returned with respect to the above command. (Alarm 1 is ON.)

[Response]

STX\$+ “0101OK18D” +ETX\$+CR\$

↑ Alarm has been ON since 1 was returned.

BWR Writes data into I relays on a bit-by-bit basis.

● Function

Writes ON/OFF data into a sequence of contiguous I relays by the specified number of bits, starting at a specified I relay number.

- The number of bits to be written at a time is 1 to 256.
- For the format of response in the event of failure, see subsection 3.1.2.
- The command shown below includes a checksum function. When performing communication without checksum, do not include the 2-byte checksum element in the command.

● Command/Response (for normal operation)

Number of Bytes	1	2	2	1	3	5	1	3	1	1	1
Command element	STX	Address number (ADR)	CPU number 01	0	BWR	I relay number	Comma or space	Number of bits (n)	Comma or space	d1	d2

Command (continued)

...	1	2	1	1
...	dn	Checksum	ETX	CR

Write information is “0” to set OFF or “1” to set ON.

dn: write data of the specified number of bits (n = 1 to 256)
 dn = 0 (OFF)
 dn = 1 (ON)

Number of Bytes	1	2	2	2	2	1	1
Response element	STX	Address number (ADR)	CPU number 01	OK	Checksum	ETX	CR

● Example

Setting the user-defined flag of the GREEN Series with address number 01 to ON.

The following command writes ON into the user-defined flag (I0865) at address number 01.

[Command]

STX\$+ “01010BWRI0865, 001, 113” +ETX\$+CR\$

Note: The user-defined flags (I relays) are flags that the user can freely read/write. For user’s read/write-accessible areas, see GREEN Series Communication Reference (IM 05G01B02-02E).

“OK” is returned in response to the command above.

[Response]

STX\$+ “0101OK5C” +ETX\$+CR\$

BRR Reads I relays on a bit-by-bit basis in a random order.

● Function

Reads the ON/OFF statuses of the individual I relays specified in a random order by the specified number of bits.

- The number of bits to be read at a time is 1 to 32.
- For the format of response in the event of failure, see subsection 3.1.2.
- The command shown below includes a checksum function. When performing communication without the checksum, do not include the 2-byte checksum element in the command.

● Command/Response (for normal operation)

Number of Bytes	1	2	2	1	3	2	5	1	5	1
Command element	STX	Address number (ADR)	CPU number 01	0	BRR	Number of bits (n)	I relay number 1	Comma or space	I relay number 2	Comma or space

Command (continued)

...	5	2	1	1
...	I relay number n	Checksum	ETX	CR

Number of Bytes	1	2	2	2	1	1	...	1	2	1	1
Response element	STX	Address number (ADR)	CPU number 01	OK	d1	d2	...	dn	Checksum	ETX	CR

The response is “0” when the status is OFF or “1” when ON.

(dn: read data of the specified number of bits (n = 1 to 32)
 dn = 0 (OFF)
 dn = 1 (ON))

● Example

Reading the statuses of alarms 1 and 4 of the GREEN Series with address number 05

The following command reads the statuses of alarm 1 (I0097) and alarm 4 (I0101) at address number 05.

[Command]

STX\$+ “05010BRR02I009Z, I01018E” +ETX\$+CR\$

In response to the command above, the ON and OFF responses are returned for alarms 1 and 4 respectively.

[Response]

STX\$+ “0501OK10C1” +ETX\$+CR\$

↑ Alarm 1 is ON, and alarm 4 is OFF.

BRW Writes data into I relays on a bit-by-bit basis in a random order.

● Function

Writes ON/OFF statuses in the individual I relays specified in a random order by the specified number of bits.

- The number of bits to be written at a time is 1 to 32.
- For the format of response in the event of failure, see subsection 3.1.2.
- The command shown below includes the checksum function. When performing communication without the checksum, do not include the 2-byte checksum element in the command.

● Command/Response (for normal operation)

Number of Bytes	1	2	2	1	3	2	5	1	1	1	5
Command element	STX	Address number (ADR)	CPU number 01	0	BRW	Number of bits (n)	I relay number 1	Comma or space	d1	Comma or space	I relay number 2

Command (continued)

1	1	1	...	5	1	1	2	1	1
Comma or space	d2	Comma or space	...	I relay number n	Comma or space	dn	Checksum	ETX	CR

Write information is “0” to set OFF or “1” to set ON.

dn: write data of the specified number of bits (n = 1 to 32)
 dn = 0 (OFF)
 dn = 1 (ON)

Number of Bytes	1	2	2	2	2	1	1
Response element	STX	Address number (ADR)	CPU number 01	OK	Checksum	ETX	CR

● Example

Setting four user-defined flags of the GREEN Series with address number 05 to ON, OFF, OFF, and ON.

The following command sets the four user-defined flags (I0721, I0722, I0723, and I0724) at address number 05 to ON, OFF, OFF, and ON, respectively.

[Command]

STX\$+ “05010BRW04I0721, 1, I0722, 0, I0723, 0, I0724, 18D” +ETX\$+CR\$

Note: The user-defined flags (I relays) are flags that the user can freely read/write. For user’s read/write-accessible areas, see GREEN Series Communication Reference (IM 05G01B02-02E).

“OK” is returned in response to the command above.

[Response]

STX\$+ “0501OK60” +ETX\$+CR\$

BRS Specifies I relays to be monitored on a bit-by-bit basis.

● Function

Specifies the numbers of I relays to be monitored on a bit-by-bit basis. Note that this command simply specifies I relays. Actual monitoring is performed by the BRM command after the I relay numbers are specified with this command.

When the volume of data is large and you wish to increase the communication rate, it is effective to use a combination of the BRS and BRM commands rather than the BRD command. If the power supply is turned off, the specified I relay numbers will be erased.

- The number of registers to be specified at a time is 1 to 32.
- For the format of response in the event of failure, see subsection 3.1.2.
- The command shown below includes the checksum function. When performing communication without the checksum, do not include the 2-byte checksum element in the command.

● Command/Response (for normal operation)

Number of Bytes	1	2	2	1	3	2	5	1	5	1
Command element	STX	Address number (ADR)	CPU number 01	0	BRS	Number of bits (n)	I relay number 1	Comma or space	I relay number 2	Comma or space

Command (continued)

...	5	2	1	1
...	I relay number n	Checksum	ETX	CR

Number of Bytes	1	2	2	2	2	1	1
Response element	STX	Address number (ADR)	CPU number 01	OK	Checksum	ETX	CR

● Example

Monitoring the stop status of the GREEN Series with address number 05

The following command monitors the stop status (I0067) at address number 05.

(This command is used simply for specifying registers.)

[Command]

STX\$+ "05010BRS01I006754" +ETX\$+CR\$

"OK" is returned in response to the command above.

[Response]

STX\$+ "0501OK60" +ETX\$+CR\$

BRM Monitors I relays on a bit-by-bit basis.

● Function

Reads the ON/OFF statuses of the I relays that have been specified in advance by the BRS command.

- Before executing this command, the BRS command must always be executed to specify which I relays are to be monitored. If no relay has been specified, error code 06 is returned. This error also occurs if the power supply is turned off.
- For the format of response in the event of failure, see subsection 3.1.2.
- The command shown below includes the checksum function. When performing communication without the checksum, do not include the 2-byte checksum element in the command.

● Command/Response (for normal operation)

Number of Bytes	1	2	2	1	3	2	1	1
Command element	STX	Address number (ADR)	CPU number 01	0	BRM	Checksum	ETX	CR

Number of Bytes	1	2	2	2	1	1	1	...	1	2	1	1
Response element	STX	Address number (ADR)	CPU number 01	OK	d1	d2	d3	...	dn	Checksum	ETX	CR

The response is “0” when the status is OFF and “1” when ON.

$\left(\begin{array}{l} \text{dn: read data of the number of bits specified by the BRS command (n = 1 to 32)} \\ \text{dn = 0 (OFF)} \\ \text{dn = 1 (ON)} \end{array} \right)$

● Example

Monitoring the stop status of the GREEN Series with address number 05

(This command reads the statuses of the I relays specified by the BRS command.)

[Command]

STX\$+ “05010BRMD7” +ETX\$+CR\$

The ON/OFF status of the I relay is returned in response to the command above.

[Response]

STX\$+ “0501OK191” +ETX\$+CR\$

↑ The I relay is ON.

WRD Reads D registers and I relays on a word-by-word basis.

● Function

Reads a sequence of contiguous register information on a word-by-word basis by the specified number of words, starting at the specified register number.

- The number of words to be read at a time is 1 to 64.
- For the format of response in the event of failure, see subsection 3.1.2.
- The command shown below includes the checksum function. When performing communication without the checksum, do not include the 2-byte checksum element in the command.

● Command/Response (for normal operation)

Number of Bytes	1	2	2	1	3	5	1	2	2	1	1
Command element	STX	Address number (ADR)	CPU number 01	0	WRD	Register number	Comma or space	Number of words (n)	Checksum	ETX	CR

Number of Bytes	1	2	2	2	4	4	...	4	2	1	1
Response element	STX	Address number (ADR)	CPU number 01	OK	dddd1	dddd2	...	ddddn	Checksum	ETX	CR

The response is returned in a 4-digit character string (0000 to FFFF) in a hexadecimal pattern.

ddddn: read data of the specified number of words
 ddddn = character string in a hexadecimal pattern
 n = 1 to 64

● Example

Reading a measured input value of the GREEN Series with address number 03

The following command reads the measured input value (D0003) at address number 03.

[Command]

STX\$+ "03010WRDDD0003, 0175" +ETX\$+CR\$

The measured input value 200 (00C8 (HEX)) is returned in response to the command above.

[Response]

STX\$+ "0301OK00C839" +ETX\$+CR\$

WWR Writes data into D registers and I relays on a word-by-word basis.

● Function

Writes information into a sequence of contiguous registers on a word-by-word basis by the specified number of words, starting at the specified register number.

- The number of words to be written at a time is 1 to 64.
- For the format of response in the event of failure, see subsection 3.1.2.
- The command shown below includes the checksum function. When performing communication without the checksum, do not include the 2-byte checksum element in the command.

● Command/Response (for normal operation)

Number of Bytes	1	2	2	1	3	5	1	2	1	4
Command element	STX	Address number (ADR)	CPU number 01	0	WWR	Register number	Comma or space	Number of words (n)	Comma or space	dddd1

Command (continued)

4	...	4	2	1	1
dddd2	...	ddddn	Checksum	ETX	CR

Write information is specified in a 4-digit character string (0000 to FFFF) in a hexadecimal pattern.

(ddddn: write data of the specified number of words
 ddddn = character string in a hexadecimal pattern
 n = 1 to 64)

Number of Bytes	1	2	2	2	2	1	1
Response element	STX	Address number (ADR)	CPU number 01	OK	Checksum	ETX	CR

● Example

Writing “200” into the target setpoint of the GREEN Series controller with address number 03.

The following command writes data 200 (00C8 (HEX)) into the target setpoint (D0301) at address number 03.

[Command]

STX\$+ “03010WWRD0301, 01, 00C890” +ETX\$+CR\$

“OK” is returned in response to the command above.

[Response]

STX\$+ “0301OK5E” +ETX\$+CR\$

WRR Reads D registers and I relays on a word-by-word basis in random order.

● Function

Reads the statuses of the individual registers, on a word-by-word basis, specified in a random order by the specified number of words.

- The number of words to be read at a time is 1 to 32.
- For the format of response in the event of failure, see subsection 3.1.2.
- The command shown below includes the checksum function. When performing communication without the checksum, do not include the 2-byte checksum element in the command.

● Command/Response (for normal operation)

Number of Bytes	1	2	2	1	3	2	5	1	5	1
Command element	STX	Address number (ADR)	CPU number 01	0	WRR	Number of words (n)	Register number 1	Comma or space	Register number 2	Comma or space

Command (continued)

...	5	2	1	1
...	Register number (n)	Checksum	ETX	CR

Number of Bytes	1	2	2	2	4	4	...	4	2	1	1
Response element	STX	Address number (ADR)	CPU number 01	OK	ddd1	ddd2	...	dddn	Checksum	ETX	CR

The response is returned in a 4-digit character string (0000 to FFFF) in a hexadecimal pattern. dddn = character string in a hexadecimal pattern (n = 1 to 32)

● Example

Reading the measured input and control output values of the GREEN Series with address number 10.

The following command reads the measured input value (D0003) and control output value (D0005) at address number 10.

[Command]
 STX\$+ "10010WRR02D0003, D00058B" +ETX\$+CR\$

The measured input value 200 (00C8 (HEX)) and output value 50 (0032 (HEX)) are returned as the response to the above command.

[Response]
 STX\$+ "1001OK00C80032FC" +ETX\$+CR\$

WRW Writes data into D registers and I relays on a word-by-word basis in random order.

● **Function**

Writes register information specified for each register into the registers specified in a random order by the specified number of words.

- The number of words to be written at a time is 1 to 32.
- For the format of response in the event of failure, see subsection 3.1.2.
- The command shown below includes the checksum function. When performing communication without the checksum, do not include the 2-byte checksum element in the command.

● **Command/Response (for normal operation)**

Number of Bytes	1	2	2	1	3	2	5	1	4	1
Command element	STX	Address number (ADR)	CPU number 01	0	WRW	Number of words (n)	Register number 1	Comma or space	dddd1	Comma or space

Command (continued)

5	1	4	...	5	1	4	2	1	1
Register number 2	Comma or space	dddd2	...	Register number n	Comma or space	ddddn	Checksum	ETX	CR

Write information is specified in a 4-digit character string (0000 to FFFF) in a hexadecimal pattern.

(dddd: repetition of register numbers and write information of the specified number of words
 dddd = character string in a hexadecimal pattern
 n = 1 to 32)

Number of Bytes	1	2	2	2	2	1	1
Response element	STX	Address number (ADR)	CPU number 01	OK	Checksum	ETX	CR

● **Example**

Writing "20.0" into the target setpoint and "15.0" into the alarm-1 setpoint of the GREEN Series with address number 10.

The following command writes

"20.0" into the target setpoint (D0301) and "15.0" into the alarm-1 setpoint (D0915) at address number 10.

[Command]

STX\$+ "10010WRW02D0301, 00C8, D0915, 00969D" +ETX\$+CR\$

Target setpoint: 200

Alarm setpoint: 150

"OK" is returned in response to the command above.

[Response]

STX\$+ "1001OK5C" +ETX\$+CR\$

WRS Specifies the D registers and I relays to be monitored on a word-by-word basis.

● **Function**

Specifies the numbers of the registers to be monitored on a word-by-word basis. Note that this command simply specifies the registers. Actual monitoring is performed by the WRM command after the register numbers are specified by this command.

If the volume of data is large and you wish to increase the communication rate, it is effective to use a combination of the WRS and WRM commands rather than the WRD command. If the power supply is turned off, the register numbers specified will be erased.

- The number of words to be specified at a time is 1 to 32.
- For the format of response in the event of failure, see subsection 3.1.2.
- The command shown below includes the checksum function. When performing communication without the checksum, do not include the 2-byte checksum element in the command.

● **Command/Response (for normal operation)**

Number of Bytes	1	2	2	1	3	2	5	1	5	1
Command element	STX	Address number (ADR)	CPU number 01	0	WRS	Number of words (n)	Register number 1	Comma or space	Register number 2	Comma or space

Command (continued)

...	5	2	1	1
...	Register number n	Checksum	ETX	CR

Number of Bytes	1	2	2	2	2	1	1
Response element	STX	Address number (ADR)	CPU number 01	OK	Checksum	ETX	CR

● **Example**

Monitoring the measured input value of the GREEN Series with address number 01.

The following command monitors the measured input value (D0003) at address number 01.

(This command simply specifies the registers.)

[Command]

STX\$+ "0101WRS01D000356" +ETX\$+CR\$

CPU number: 01

↑ D register number: D0003

"OK" is returned in response to the command above.

[Response]

STX\$+ "0101OK5C" +ETX\$+CR\$

WRM Monitors the D register and I relays on a word-by-word basis.

● Function

Reads the information of the registers that have been specified in advance by the WRS command.

- Before executing this command, the WRS command must always be executed to specify which registers are to be monitored. If no register has been specified, error code 06 is returned. This error also occurs if the power supply is turned off.
- For the format of response in the event of failure, see subsection 3.1.2.
- The command shown below includes the checksum function. When performing communication without the checksum, do not include the 2-byte checksum element in the command.

● Command/Response (for normal operation)

Number of Bytes	1	2	2	1	3	2	1	1
Command element	STX	Address number (ADR)	CPU number 01	0	WRM	Checksum	ETX	CR

Number of Bytes	1	2	2	2	4	4	...	4	2	1	1
Response element	STX	Address number (ADR)	CPU number 01	OK	dddd1	dddd2	...	ddddn	Checksum	ETX	CR

The response is returned in a 4-digit character string (0000 to FFFF) in a hexadecimal pattern.

{

 dddd_n: read data of the number of words specified by the WRS command
 dddd_n = character string in a hexadecimal pattern
 n = 1 to 32

}

● Example

Monitoring the measured input value of a GREEN Series controller with address number 01

The following command monitors the measured input value (D0003) at address number 01.

(This command reads the status of the register specified by the WRS command.)

[Command]

STX\$+ "01010WRME8" +ETX\$+CR\$

↑ CPU number: 01

The measured input value 200 (00C8 (HEX)) is returned in response to the command above.

[Response]

STX\$+ "0101OK00C837" +ETX\$+CR\$

↑ Measured input value: 200

INF Reads the model, version, and revision information.

● Function

Reads the model code, version number, and revision number of the GREEN Series controller.

- For the format of response in the event of failure, see subsection 3.1.2.

● Command/Response (for normal operation)

Number of Bytes	1	2	2	1	3	1	2	1	1
Command element	STX	Address number (ADR)	CPU number 01	Response time: 0	INF	6	Checksum	ETX	CR

Number of Bytes	1	2	2	2	8	8	4	4
Response element	STX	Address number (ADR)	CPU number 01	OK	Model code: U□□□□□-□□ (Note 1)	Version and revision numbers (Note 2)	0001 (Note 3)	(Note 4)

Response (continued)

4	4	2	1	1
(Note 5)	0000 (Note 6)	Checksum	ETX	CR

Note 1: Model name, control type, and options of GREEN Series Controller

- Model code of UT750 UT750-□□
 - 0: No option
 - 1: With communication, auxiliary analog (remote) input
 - 0: Single-loop type
 - 1: Position proportional type
 - 5: Dual-loop type

- Model code of UP750 UP750-□□
 - 0: No option
 - 1: With communication, auxiliary analog input
 - 0: Single-loop type
 - 5: Dual-loop type

- Model code of UT55□ UT55□-□□□
 - 0: No option
 - 1: With communication, auxiliary analog (remote) input, 6 additional DIs and 4 additional DOs
 - 2: With communication, auxiliary analog (remote) input, and 1 additional DI
 - 3: With 5 additional DIs and 4 additional DOs
 - 4: With auxiliary analog (remote) input and 1 additional DI
 - 0: Standard type
 - 1: Position proportional type
 - 2: Heating/cooling type
 - 3: Standard type (with 24V DC sensor power supply)
 - 4: Position proportional type (with 24V DC loop power supply)
 - 0: UT550
 - 1: UT551

- Model code of UT520 UT520-□□
 - 0: No option
 - 7: With communication, auxiliary analog (remote) input, and 2 additional DIs
 - 8: With auxiliary analog (remote) input and 2 additional DIs
 - 0: Standard type

- Model code of UP550 UP550-□□
 - 0: No option
 - 1: With communication, auxiliary analog input, and 1 additional DI
 - 0: Standard type
 - 1: Position proportional type
 - 2: Heating/cooling type

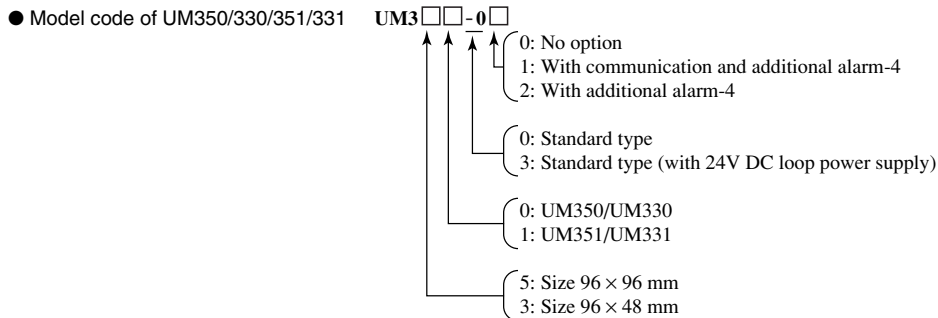
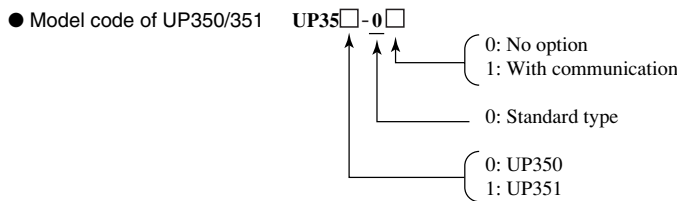
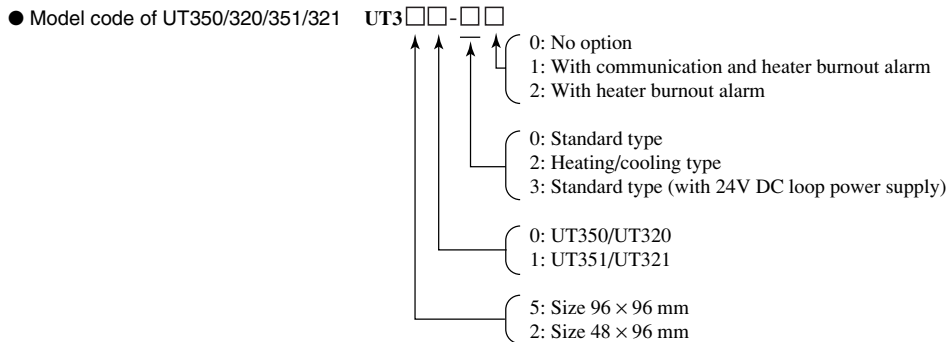
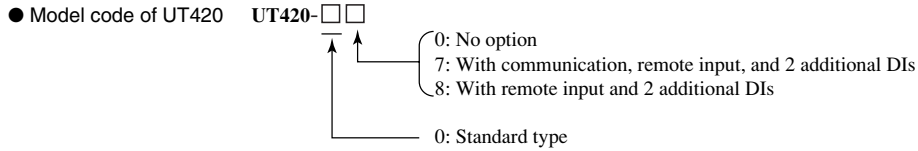
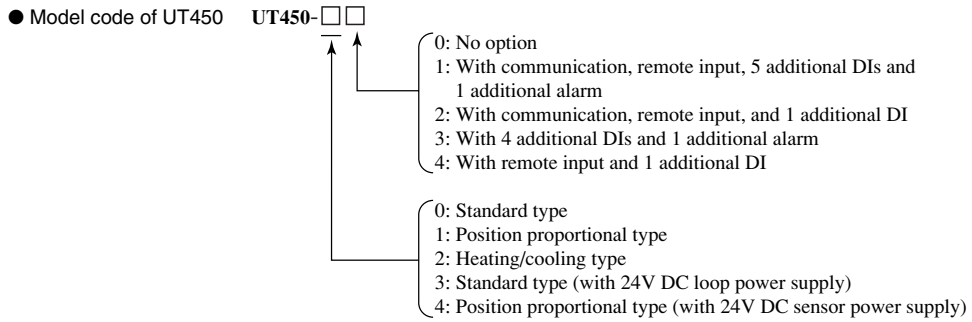

Note 2: Version and revision numbers

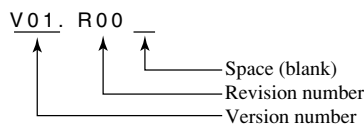

Note 3: Valid in Non-user-specifiable mode.* The value in this field is the first read register number, which is "0001" for all models.

Note 4: Valid in Non-user-specifiable mode.* The value in this field is the number of registers read in Non-user-specifiable mode: "0008" for UT350/UT320/UT351/UT321 and UP350/UP351, and "0025" for all other models.

Note 5: Valid in Non-user-specifiable mode.* The value in this field is the first write register number: "0001" for UT350/UT320/UT351/UT321 and UP350/UP351, and "0201" for all other models.

Note 6: Valid in Non-user-specifiable mode.* The value in this field is the number of registers written in Non-user-specifiable mode, which is "0000" for all models.

*: One of the convenient modes used when communicating with FA-M3 with UT-link module. (See section 3.2.)

UMD Sets the UT/UP mode (control function).

● Function

Sets the control function of UT750, UT550/UT520, UT551, and UP750/UP550.

- Changing the control function with this command initializes all the controller’s parameters to default values (factory settings), except for communication parameters.
- After receiving this command, the controller is not able to receive the next command for about 10 seconds. So, during this period, do not send any command from the higher-level device.
- For the format of response in the event of failure, see subsection 3.1.2.

● Command/Response (for normal operation)

Number of Bytes	1	2	2	1	3	2	2	1	1
Command element	STX	Address number (ADR)	CPU number 01	Response time: 0	UMD	Parameter	Checksum	ETX	CR

No response is returned for this command.

USM Changes the PV input sampling period.

● Function

Changes the PV input sampling period of UT750, UT550/UT520, UT551, and UP750/UP550.

- Changing the sampling period with this command initializes all the controller’s parameters to their default values (factory settings), except for communication parameters.
- After receiving this command, the controller is not able to receive the next command for about 10 seconds. So, during this period, do not send any command from the higher-level device.
- For the format of response in the event of failure, see subsection 3.1.2.

● Command/Response (for normal operation)

Number of Bytes	1	2	2	1	3	1	2	1	1
Command element	STX	Address number (ADR)	CPU number 01	Response time: 0	USM	(Note)	Checksum	ETX	CR

No response is returned for this command.

Note: Values to set and corresponding periods

Value to set	PV input sampling period
0	50ms
1	100ms
2	200ms
3	500ms

3.2.4 Response Error Codes



See Also

Subsection 3.1.2, Configuration of Response, for the structure of the response in the event of an error.

The error codes (EC1) and detailed error codes (EC2) of response are as follows.

Table 3.4 Error Codes (EC1)

Error code	Meaning	Causes
02	Command error	<ul style="list-style-type: none"> The command does not exist. Command not executable
03	Internal register specification error	<ul style="list-style-type: none"> Specified register number does not exist. In handling bit registers (I relays) on a word-by-word basis, its specification is not correct.
04	Out of setting range	<ul style="list-style-type: none"> A character other than 0 and 1 was used for bit setting. A value other than 0000 to FFFF was specified in the word specification. The start address specified for data loading/saving is out of the address range.
05	Number of data error	<ul style="list-style-type: none"> Specified number of bits or words is too large. The number of data or registers specified and the number of parameters for them are inconsistent.
06	Monitor error	<ul style="list-style-type: none"> An attempt was made to execute monitoring without specifying any device to be monitored (BRS or WRS).
08	Parameter error	<ul style="list-style-type: none"> Wrong parameter.
42	Sum error	<ul style="list-style-type: none"> The sum does not match.
43	Internal buffer overflow	<ul style="list-style-type: none"> Too much data was received.
44	Timeout between received characters	<ul style="list-style-type: none"> No terminal character or ETX is received.

Table 3.5 Detailed Error Codes (EC2)

Error code (EC1)	Meaning	Detailed error code (EC2)
03	Internal register specification error	Indicates the parameter number where an error occurred (HEX). This is the number of a parameter in sequence that first resulted in an error when counted from the leading parameter. Example: <div style="text-align: right; margin-right: 100px;">Error in internal register specification</div> <div style="text-align: center;">↓</div> STX 01010BRW <u>30</u> I0003, <u>1</u> , I0002, <u>0</u> , A0005 Parameter number 1 2 3 4 5 6 In this case, EC1 = 03 and EC2 = 06
04	Out of setting range	
05	Number of data error	
08	Parameter error	

For EC1 error codes other than those noted above, EC2 has no meaning.

3.3 Example of BASIC Program for Send and Receive

This section shows an example of a command sending and response receiving program created with Microsoft Quick BASIC*2 for PC/AT*1 (or compatible machines).

The communication conditions of the GREEN Series controllers and those of the PC (e.g., communication rate) must agree with each other. Set the communication rate (baud rate) of the PC using the SWITCH command of MS-DOS*3 . For how to use the SWITCH command, refer to the User's Reference Manual of MS-DOS.

Set the parity, character bit length, stop bit length, and others in an OPEN statement.

*1 PC/AT is the product of IBM Corporation.

*2 Microsoft Quick BASIC is a registered trademark of Microsoft Corporation.

*3 MS-DOS is a registered trademark of Microsoft Corporation.

Example of the Program Created Using Microsoft Quick BASIC Version 7.1

```

1000 ' === Main routine ===
1010 STX$=CHR$(2)           ' Define
1020 ETX$=CHR$(3)         ' Define
1030 CR$=CHR$(13)         ' Define
1040 RCVCHR$= ""          ' Initialize receive character string
1050 fRCVEND=0            ' Initialize flag
1060 fTIMEOUT=0           ' Initialize flag
1070 '
1080 SEND$=STX$+"01010WRDD0003,03"+ETX$ ' Create character string for send
1090 '
1100 OPEN "COM1:9600,N,8,1,ASC" FOR RANDOM AS #1 ' Open a port
1110 ON COM(1) GOSUB receivechr ' Specify interruption processing during
                                receiving
1120 ON TIME(5) GOSUB timeout    ' Specify interruption processing at timeout
1130 '
1140 PRINT #1,SEND$             ' Send
1150 COM(1) ON                  ' Permit interruption during receive
1160 TIMER ON                   ' Start timer
1170 '
1180 DO                          ' Wait for receive end or timeout
1190 LOOP WHILE fRCVEND=0 AND fTIMEOUT=0 '
1200 '
1210 TIMER OFF                  ' Stop timer
1220 COM(1) OFF                 ' Prohibit interruption during receiving
1230 CLOSE #1                   ' Close the port
1240 '
1250 PRINT ">" + SEND$          ' Display sent character string on screen
1260 PRINT "<" + RCVCHR$        ' Display received character string on screen
1270 END                          ' END
1280 '
1290 ' === subroutine ===
1300 receivechr:                ' Interruption processing during receiving
1310 CHR1$=INPUT$(1,#1)         ' Fetch characters from receive buffer one by one
1320 IF CHR1$=CR$ THEN          ' If received character string is "CR,"
1330 IF RCVCHR$=SEND$ THEN      ' If received character string is the same
                                as sent command,
1340 RCVCHR$=""                 ' received character string is initialized
                                (echo-back).
1350 fRCVEND=0                  ' receiving end flag remains initialized at 0.
1360 ELSE                        ' If received character string is different
                                from sent command,
1370 fRCVEND=1                  ' receiving end flag is set.
1380 END IF                      '
1390 ELSE                        ' If it is a character other than CR,
1400 fRCVEND=0                  ' receiving end flag remains initialized at 0.
1410 RCVCHR$=RCVCHR$+CHR1$     ' Create received character string
1420 END IF                      '
1430 RETURN
1440 '
1450 timeout:                    ' Timeout processing
1460 fTIMEOUT=1                 ' Set timeout flag
1470 RCVCHR$="Time out ! (5 sec)" + CR$ ' Character string for display on screen
                                "Time out! (5 sec)"
1480 RETURN

```

↑

* Line numbers are not required. (They are simply provided for checking the number of program steps.)30

Blank Page

4. Ladder Communication

4.1 Overview

By using ladder communication, you can easily perform communication between a PLC (sequencer) and a GREEN Series controller. This kind of communication allows for the reading/writing of D registers/B registers (internal registers of GREEN Series).



See Also

GREEN Series Communication Reference (IM 05G01B02-02E) for information about D registers and B registers.

In ladder communication, a PLC identifies each instrument by its station number, which ranges from 1 to 99.

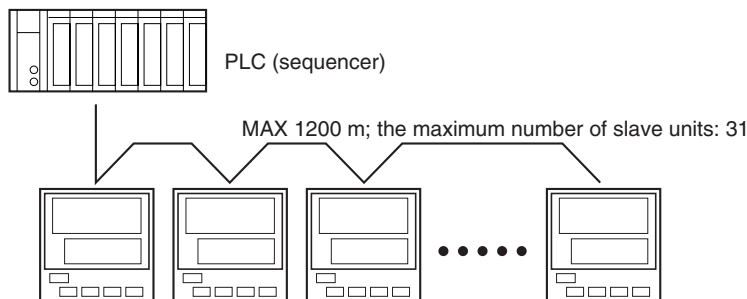

Figure 4.1 Connecting with Ladder Communication

4.1.1 Configuration of Commands

Commands sent from a PLC consist of the following elements.

Number of Bytes	1	1	2	1		1		2	1	1
Number of BCD digits	2	2	4	1	1	1	1	4	2	2
Element	Station number	CPU number 01	Parameter number	0	5 th digit	R/W	+/-	Read/write data	CR	LF
	(1)	(2)	(3)	(4)	(5)	(6)	(7)	(8)	┌ (9) ─┐	

(1) Station Number (01 to 99)

The station number is used by the PLC to identify which instrument to communicate with. (ID number of GREEN Series controller)

(2) CPU Number

This number is fixed to 01.

(3) Parameter number

For D registers, 4-digit BCD data of a D register number with its leading character "D" removed.

For B registers, 4-digit BCD data of a B register number to which 1700 is added and with its leading character "B" removed.

(4) 0

This is fixed to 0.

(5) The 5th digit

The digit on the furthest left of the EU or EUS data when it is displayed in 5 digits. (For example, if the data value is 1234.5, the 5th digit is 1.)

(6) R/W

0: Read

1: Write

(7) +/-

0: Positive data (+)

1: Negative data (-)

(8) Read/write data

For read operation, the number of data items to be read. (64 at maximum)

For write operation, setting data with a 4-digit BCD value excluding the decimal point.

(9) CR, LF

These control codes mark the end of a command. The character codes for CR and LF are CHR\$(13) and CHR\$(10), respectively.



NOTE

The UT750/UP750, UT550/UT520, UT551, and UP550 display data in 5 digits. Data that is read/written via communication also consists of 5 digits. However, if you do not need to use 5-digit data for communication, set the data display digits of the controller to no more than 4 digits.

● **Data Forms of Commands**

The table below shows the data forms of D registers/B registers.

Table 4.1 Data Forms

Data type	Data content	Data form
PV high and low limits, target setpoints, and others	Measuring range (EU) data	Numeric data not including the decimal point
Bias, deviation alarms, and others	Measuring range span (EUS) data	Numeric data not including the decimal point
Proportional bands, upper and lower limits of output, and others	% data (0.0 to 100.0%)	0 to 1000
Various modes, alarm types, and others	Seconds, absolute values, and data without unit*	Absolute value not including the decimal point

* Parameter list of GREEN series User's Manual (Reference) for information about data form.

● **Command Format for Communication**

Example: When setting the target setpoint 50.0 to a GREEN Series controller, the PLC sends the value 500 as command data without the decimal point (this is also true for both settings 5.00 or 50.0).

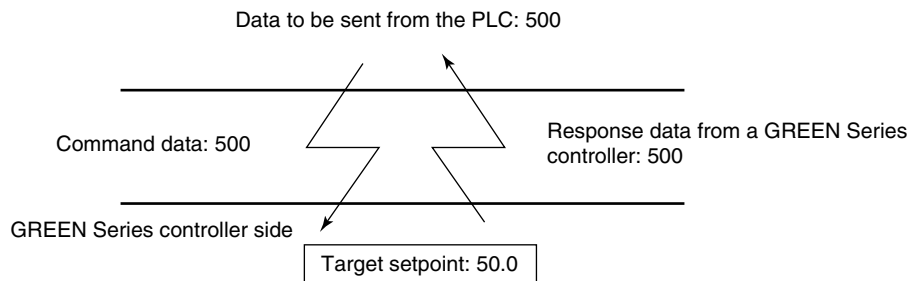

* The position of the decimal point for 500 is determined by the DP (decimal point position) parameter of the GREEN Series controller.

4.1.2 Configuration of Response

Response from a GREEN Series controller with respect to a command sent from the PLC consists of the elements shown below.

Number of Bytes	1	1	2	1		1		2	1	1
Number of BCD digits	2	2	4	1	1	1	1	4	2	2
Element	Station number	CPU number 01	Parameter number	0	5 th digit	R/W	+/-	Read/write data	CR	LF

When responding to a data read command, the length of this part varies: 64 data items at maximum.

4.2 Communication with PLC

With ladder communication you cannot specify D registers/B registers (internal registers of GREEN Series) by using their numbers as is. Set register numbers as shown below.

- D register: 4-digit BCD value of the register number (with “D” removed)
- B register: 4-digit BCD value of the result obtained by adding 1700 to the register number (with “B” removed)

PLCs that can communicate with GREEN Series controllers are those capable of using the ladder communication protocol.

PLCs that can be connected to a GREEN Series controller are listed below.

Table 4.2 List of PLCs that can be connected

Supplier	Product	Requirement	Remarks
Yokogawa Electric Corporation	FA500	With communication module (RZ91-ON)	(Note)
	FA-M3	With communication module (F3RZ91-ON)	
Mitsubishi Electric Corporation, or others	MELSEC-A series and others	With computer link unit	
	PLCs that can communicate in handshaking mode.	With computer link unit	

Note: For more information about the PLCs listed above, contact the supplier.

For details, see the instruction manual of the PCL to be connected.

Examples of ladder communication programs are shown in section 4.4.

4.2.1 Reading Data

Shown below are the configurations of commands and responses when data in a GREEN Series controller is read by the PLC.

● Commands

Number of bytes	1	1	2	1	1	2	1	1		
Number of BCD digits	2	2	4	1	1	4	2	2		
Element	Station number	CPU number 01	Parameter number	0	5 th digit	0	0	Number of data items to read (n)	CR	LF

● Responses

Number of bytes	1	1	2	1	1	2	1	1	2				
Number of BCD digits	2	2	4	1	1	4	1	1	4				
Element	Station number	CPU number 01	Parameter number	0	5 th digit	0	+/-	dddd1	0	5 th digit	0	+/-	dddd2

Data of the parameter number (first data)
Second data

...	1	1	2	1	1		
	1	1	1	1	4	2	2
...	0	5 th digit	0	+/-	ddddn	CR	LF

nth data

● Example

Reading a measured input value of a GREEN Series controller with station number 01
 The following command reads the measured input value (D0003) at station number 01.

[Command] "01010003000000010D0A"

In response to the command above, the measured input value "200" is returned.

[Response] "01010003000002000D0A"

↑ "0200" has been returned.

4.2.2 Writing Data

Shown below are the configurations of commands and responses when data is written to a GREEN Series controller from the PLC.

● Commands

Number of bytes	1	1	2	1		1		2	1	1
Number of BCD digits	2	2	4	1	1	1	1	4	2	2
Element	Station number	CPU number 01	Parameter number	0	5 th digit	1	+/-	dddd	CR	LF

● Responses

Number of bytes	1	1	2	1		1		2	1	1
Number of BCD digits	2	2	4	1	1	1	1	4	2	2
Element	Station number	CPU number 01	Parameter number	0	5 th digit	1	+/-	dddd	CR	LF

● Example

Writing “200” to the target setpoint 1 value of a GREEN Series controller with station number 01.

The following command writes “200” to the target setpoint 1 (D0301) at station number 01.

[Command] “01010301001002000D0A”

In response to the command above, the following response is returned. (Target setpoint 1 value is 200.)

[Response] “01010301001002000D0A”

↑ “0200” has been returned.

4.2.3 Response Error Codes

The PLC may receive the following responses in the event of error.

Table 4.4 Response in the Event of Error

Error condition	Data sent from PLC	Data PLC receives
A non-existing parameter number was sent.	0101 0000 0000 0001 CRLF "0000" is the wrong parameter number.	0101 0000 0000 FFFF CRLF "FFFF" is returned.
Characters other than BCD codes were used in an element other than a station number.	0101 0123 0000 000B CRLF 0101 0123 000B 0000 CRLF 0101 0123 0B00 0000 CRLF 0101 012B 0000 0000 CRLF	0101 FFFF FFFF FFFF CRLF
An LF code (0A) was used in an element other than a station number.	0101 0123 0000 000A CRLF 0101 0123 000A 0000 CRLF 0101 0123 0A00 0000 CRLF 0101 01 0A 0000 0000 CRLF	No response
Specified station number does not match any of the controllers connected.	01 03 0123 0000 0000 CRLF 00 01 0123 0000 0000 CRLF 33 01 0123 0000 0000 CRLF	No response
The write data was outside the range.	0101 0123 0011 9999 CRLF "9999" is the data outside the range.	0101 0123 0011 0050 CRLF "0050" is the current setting of the parameter.
Wrong command length. (Command length is 10 bytes including CR and LF codes.)	0101 0123 0000 00 CRLF 0101 0123 00 0000 CRLF 0101 0 0000 0000 CRLF	No response
A timeout occurred when sending data. (Timeout: 5 seconds)	—	No response
Send buffer overflowed. (The buffer capacity is 199 bytes.)	—	No response
A framing error or a parity error occurred.	—	No response



NOTE

If you try to read data of a parameter number that is not in the D register table or B register table, or that corresponds to a vacant cell in that table, no error occurs and 0 is returned.

Blank Page

5. MODBUS Communication

5.1 Overview

A MODBUS communication protocol is one of the protocols used to communicate with devices such as PCs, PLCs (sequencers), and graphic panels. Via this communication protocol, these devices can exchange data with GREEN Series controllers by reading/writing the internal registers (D registers/B registers) of a GREEN Series controller.

Hereafter, PCs, PLCs (sequencers), and graphic panels are referred to as “higher-level devices.”



See Also

GREEN Series Communication Reference (IM 05G01B02-02E) for information about internal registers.

For the MODBUS communication of the GREEN Series, two transmission modes are supported: ASCII mode (ASCII system) and RTU mode (binary system).

Table 5.1 ASCII and RTU Modes

Item	ASCII mode	RTU mode
Number of data bits	7 bits (ASCII)	8 bits (binary)
Message start mark	: (colon)	Unnecessary
Message end mark	CR + LF	Unnecessary
Message length (Note 1)	2N + 1	N
Data time intervals	1 second or less	24-bit time or less (Note 2)
Error detection	Longitudinal redundancy check: LRC	Cyclic redundancy check: CRC-16

Note 1: When the message length in the RTU mode is assumed to be “N.”

Note 2: When the communication rate is 9600 bps, 1÷ 9600 × 24 sec. or less.

In MODBUS communication, a higher-level device identifies each GREEN Series controller with a communication address, which ranges from 1 to 99. However, broadcasting, which requires no address number, is possible with some of the commands. For more information, see subsection 5.2.2.

The next section will discuss the configuration of messages. 5.2 Saving/Reading Data on/ from Disk and Comparing Data Values

5.1.1 Configuration of Messages

Messages sent from a higher-level device to a GREEN Series controller consist of the following elements.

Element	Start of Message Mark	Address Number (ADR)	Function Code	Data	Error Check	End of Message Mark
Number of bytes in RTU mode	None	1	1	2n	2	None
Number of bytes in ASCII mode	1	2	2	4n	2	2
	(1)	(2)	(3)	(4)	(5)	(6)

(1) Start of Message Mark

This mark indicates the start of a message. Note that only ASCII mode requires a colon.

(2) Address Number (1 to 99)

An address number is used by a higher-level device to identify which GREEN Series controller to communicate with. (ID number of GREEN Series controller)

(3) Function Code (See subsection 5.2.1, “List of Function Codes”)

The function code specifies a command (function code) from the higher-level device.

(4) Data

This element specifies D registers/B register numbers, the number of D/B registers, parameter values, and so on in accordance with the function code.

(5) Error Check

In RTU mode carried out by the cyclic redundancy check (CRC-16) system.

In ASCII mode carried out by the longitudinal redundancy check (LRC) system.

(6) End of Message Mark

This mark indicates the end of a message.

Note that only ASCII mode requires CR.

● Message format for communication

Example: When setting the target setpoint “50.00” to a GREEN Series controller, the higher-level device sends the message data “1388,” which is the hexadecimal value of “5000” - decimal point removed from “50.00” (this is also true for setting 5.000 or 500.0).

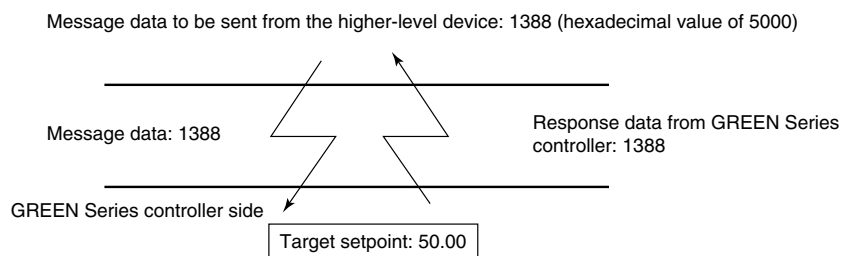

* The position of the decimal point for “5000” is determined by the DP (decimal point position) parameter of the GREEN Series controller.

5.2 Communication with Higher-level Device

When you use a commercially available SCADA or the like or a user-created communication program, you must be careful when specifying D registers/B register numbers contained in messages because in both cases, you cannot use the original D registers/B register numbers as they are.

● To specify D registers

- (1) When using a commercially available SCADA or the like, specify D register numbers by changing them into reference numbers. To change them into a reference number, replace the D register number's leading character "D" with "4." (When using a DDE server or others, specify these reference numbers.)
- (2) In a user-created communication program, specify a D register using the hexadecimal number of the value obtained by subtracting "40001" from the D register's reference number. (Specify this hexadecimal number.)

Example: To specify target setpoint "D0301"

- For a message using commercially available SCADA or the like, specify reference number "40301."
- For a message in a user-created communication program, specify "012C," the hexadecimal number of "0300," which is obtained by subtracting 40001 from the reference number.

● To specify B registers

- (1) When using a commercially available SCADA or the like, specify B register numbers by changing them into reference numbers. To change into a reference number, add 1700 to the B register number and replace the B register number's leading character "B" with "4." (When using a DDE server or others, specify these reference numbers.)
- (2) In a user-created communication program, specify a B register using the hexadecimal number of the value obtained by subtracting "40001" from the B register's reference number. (Specify this hexadecimal number.)

Example: To specify PID No. "B0115"

- For a message using commercially available SCADA or the like, specify reference number "41815."
- For a message in a user-created communication program, specify "0716," the hexadecimal number of "1814," which is obtained by subtracting 40001 from the reference number.

5.2.1 List of Function Codes

Function codes are command words used by the higher-level device to obtain the D registers/B register information of GREEN Series controllers.

Table 5.2 Function Codes

Code	Function	Description
03	Reads data from multiple registers.	Capable of reading data from a maximum of 64 successive registers.
06	Writes data into a register.	Capable of writing data to one register.
08	Performs loop back test.	See subsection 5.2.3.
16	Writes data into multiple D/B registers.	Capable of writing data into a maximum of 32 successive registers.

- The write function codes will not write into read-only or disabled D registers/B registers.
- Broadcast addressing is possible with function codes 06 and 16 only. (Also in this case, read-only or disabled D/B registers will not be written.)

5.2.2 Specifying Broadcast

Broadcast addressing allows the corresponding multiple GREEN SERIES controllers to receive the command.

- (1) In the command, specify the broadcast address "00" and execute it.
- (2) Broadcast addressing works independently of the communication address of the controller.
- (3) Broadcast addressing is applicable to write commands only.
- (4) No response is returned when broadcast addressing is used.

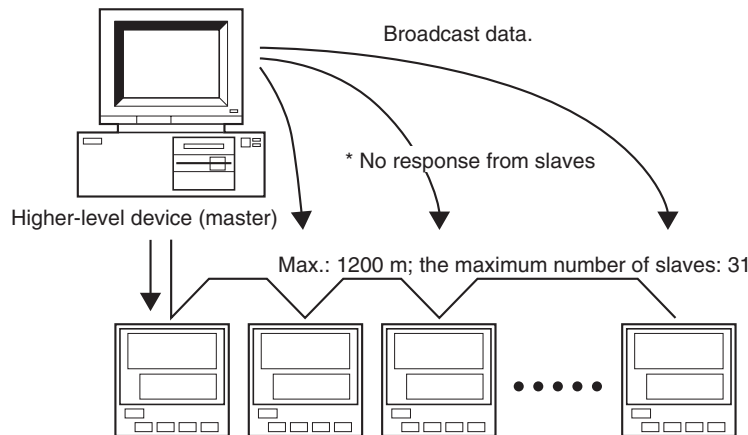

Figure 5.2 Broadcasting

5.2.3 Function Codes

03 Reads data from multiple D registers/B registers.

● Function

This function code reads the contents of successive D registers/B registers by the specified number starting at a specified D registers/B register number.

- The maximum number of D registers/B registers to be read at a time is 64.
- For the format of responses in the event of failure, see subsection 5.2.4.

● Message (for normal operation)

Element	Start of Message Mark (:)	Address Number (ADR)	Function Code (03)	Register Start Number (Upper Digit)	Register Start Number (Lower Digit)
Number of bytes in RTU mode	None	1	1	1	1
Number of bytes in ASCII mode	1	2	2	2	2

Message (continued)

Number of Registers (Upper Digit)	Number of Registers (Lower Digit)	Error Check	End of Message Mark (CR + LF)
1	1	2	None
2	2	2	2

● Response (for normal operation)

Element	Start of Message Mark (:)	Address Number (ADR)	Function Code (03)	Byte Count	Contents of Register (Upper Digit)	Contents of Register (Lower Digit)	...
Number of bytes in RTU mode	None	1	1	1	1	1	...
Number of bytes in ASCII mode	1	2	2	2	2	2	...

Response (continued)

Contents of Registers (Upper Digit)	Contents of Registers (Lower Digit)	Error Check	End of Message Mark (CR + LF)
1	1	2	None
2	2	2	2

● Example

Reading the alarm types of alarms 1 to 4 from the GREEN Series controller with address number 17.

The following message reads four successive D registers/B registers starting with alarm 1 (D0915) at address number 17 in the ASCII mode.

[Message] [:]11030392000453[CR]

↑ Start of message mark

“11”: address number 17, “03”: function code 03, “0392”: D register address 0915, “0004”: number of D registers 4, and “53”: error check

* Numbers in quotation marks are hexadecimal.

The following response is returned with respect to the message above.

[Response] [:]1103080000000100010000E2[CR]

↑ ↑ ↑ ↑
Types of alarm1, alarm2, alarm3, alarm4

“08”: byte count

16 Writes data to multiple D registers/B registers.

● Function

This function code writes data to successive D registers/B registers by the number starting from a specified D registers/B register number.

- The maximum number of D registers/B registers to be written to at the same time is 32.
- For the format of response in the event of failure, see subsection 5.2.4.
- Broadcast addressing is possible (by setting “00” to the address number).

● Message (for normal operation)

Element	Start of Message Mark (:)	Address Number (ADR)	Function Code (10)	D-Register Start Number (Upper Digit)	D-Register Start Number (Lower Digit)
Number of bytes in RTU mode	None	1	1	1	1
Number of bytes in ASCII mode	1	2	2	2	2

Message (continued)

Number of D Registers (Upper Digit)	Number of D Registers (Lower Digit)	Byte Count	Data (Upper Digit)	Data (Lower Digit)	...	Error Check	End of Message Mark (CR + LF)
1	1	1	1	1	...	2	None
2	2	2	2	2	...	2	2

● Response (for normal operation)

Element	Start of Message Mark (:)	Address Number (ADR)	Function Code (03)	Byte Count	Contents of D-Register (Upper Digit)	Contents of D-Register (Lower Digit)	...
Number of bytes in RTU mode	None	1	1	1	1	1	...
Number of bytes in ASCII mode	1	2	2	2	2	2	...

Response (continued)

Contents of D Registers (Upper Digit)	Contents of D Registers (Lower Digit)	Error Check	End of Message Mark (CR + LF)
1	1	2	None
2	2	2	2

● Example

Setting a proportional band of 200, an integral time of 10, and a derivative time of 3 to the GREEN Series controller with an address number 02.

The following message writes values 200, 10, and 3 in this order in the ASCII mode, starting with the proportional band (D0331) of address number 02.

[Message] [:]0210014A00030600C8000A0003C5[CR]

↑ Start of message mark

“02”: address number 02, “10”: function code 16, “014A”: starts register address 0331, “0003”: number of D registers 3, “06”: byte count, “00C8”: proportional band’s value 200, “000A”: integral time 10, “0003”: derivative time 3, and “C5”: error check

* Numbers in quotation marks are hexadecimal.

The following response is returned with respect to the message above.

[Response] [:]0210014A0003A0[CR]

↑ Number of registers: 3

06 Writes data to D registers/B register.

● Function

This function code writes data to a specified D registers/B register number.

- The maximum number of D registers/B registers to be written to at the same time is 1.
- For the format of response in the event of failure, see subsection 5.2.4.
- Broadcast addressing is possible (by setting “00” to the address number).

● Message (for normal operation)

Element	Start of Message Mark (:)	Address Number (ADR)	Function Code (06)	D-Register Number (Upper Digit)	D-Register Number (Lower Digit)
Number of bytes in RTU mode	None	1	1	1	1
Number of bytes in ASCII mode	1	2	2	2	2

Message (continued)

Write Data (Upper Digit)	Write Data (Lower Digit)	Error Check	End of Message Mark (CR + LF)
1	1	2	None
2	2	2	2

● Response (for normal operation)

Element	Start of Message Mark (:)	Address Number (ADR)	Function Code (06)	D-Register Number (Upper Digit)	D-Register Number (Lower Digit)
Number of bytes in RTU mode	None	1	1	1	1
Number of bytes in ASCII mode	1	2	2	2	2

Response (continued)

Write Data (Upper Digit)	Write Data (Lower Digit)	Error Check	End of Message Mark (CR + LF)
1	1	2	None
2	2	2	2

● Example

Setting 70.00 to the target setpoint of the GREEN Series with address number 01.

The following message writes “7000” to the target setpoint (D0326) at address number 01 in the ASCII mode.

[Message] [:]010601451B5840[CR]

↑ Start of message mark

“01”: address number 01, “06”: function code 06, “0145”: D register address 0326, “1B58”: target setpoint 70.00, and “40”: error check

* Numbers in quotation marks are hexadecimal.

The response of the same contents is returned with respect to the message above.

[Response] [:] 010601451B5840[CR]

↑ Target setpoint 70.00

08 Performs a loop back test.

● Function

This function code is used to check connection for communication.

- For the format of response in the event of failure, see subsection 5.2.4.
- The “00” shown below (marked with an asterisk *) are fixed.
- Any value can be selected for send data.

● Message (for normal operation)

Element	Start of Message Mark (:)	Address Number (ADR)	Function Code (08)	*00 (Upper Digit)	*00 (Lower Digit)
Number of bytes in RTU mode	None	1	1	1	1
Number of bytes in ASCII mode	1	2	2	2	2

Message (continued)

Send Data (Upper Digit)	Send Data (Lower Digit)	Error Check	End of Message Mark (CR + LF)
1	1	2	None
2	2	2	2

● Response (for normal operation)

Element	Start of Message Mark (:)	Address Number (ADR)	Function Code (08)	00 (Upper Digit)	00 (Lower Digit)
Number of bytes in RTU mode	None	1	1	1	1
Number of bytes in ASCII mode	1	2	2	2	2

Response (continued)

Send Data (Upper Digit)	Send Data (Lower Digit)	Error Check	End of Message Mark (CR + LF)
1	1	2	None
2	2	2	2

● Example

Sending data 1234h to the GREEN Series controller with address number 05 to check the connection for communication.

The following message sends “1234” (hexadecimal) to address number 05 in the ASCII mode.

[Message] [:]050800001234AD[CR]

↑ Start of message mark

“05”: address number 05, “08”: function code 08, “0000”: fixed, “1234”: send data, and “AD”: error check

* Numbers in quotation marks are hexadecimal.

When the connection is normal, the following response is returned with respect to the message above.

[Response] [:]050800001234AD[CR]

↑ “1234”: send data

5.2.4 Response Error Codes

● Message Format in the Event of an Error

If there is any inconsistency other than communication errors in a message, the GREEN Series controller does nothing but return the following message.

Element	Address Number (ADR)	Function Code*	Error Code	Error Check
Number of bytes in RTU mode	1	1	1	2
Number of bytes in ASCII mode	2	2	2	2

* In this space, a value of [function code (hexadecimal number) + 80 (hexadecimal number)] is set.

● Response Error Codes

Table 5.4 List of Error Codes

Error Code	Meaning	Cause
01	Function code error	No such function code exists.
02	Register address error	Specified address is out of the range.
03	Register count error	Specified number of D/B registers is out of the range.

● Even when a message is sent, no response is returned if:

- Transmission error (overrun, framing, parity, LRC, or CRC-16 error) was detected.
- Address in a command message is incorrect.
- Time interval between the data composing a message was 1 second or more.
- Broadcast is specified (address number: 00).

As a measure against these situations, provide a timeout processing in the communication functions or communication programs of the higher-level device.

Blank Page

6. Coordinated Operation

6.1 Overview

A system of coordinated operation is configured with a master controller and a number of slave controllers, all of which are GREEN Series controllers. The slave controllers are set to operate in the same way as the master controller. Therefore you do not have to create a communication program or to use specialized software for coordinated operation.

The controllers operate in coordination with respect to the following items.

● Target Setpoint

Note that when the master is a program controller (UP controller), slave program controllers can be made to perform program operation.

- When the controller is set up to Master or Slave:

The sending-controller always sends the target setpoint of Loop-1.

If the receiving-controller is in dual-loop mode, both loops operate using the same target setpoint.

- When the controller is set up for Master (2-loop mode) or Slave (Loop-1 or Loop-2 mode):

If the sending-controller is dual-loop type or its program pattern-2 generator* is ON, it sends the target setpoints of Loop-1 and Loop-2. (When the sending-controller is single-loop type and its program pattern-2 generator* is OFF, it sends Loop-1 target setpoint.)

The receiving-controller uses either data of Loop-1 or Loop-2 according to the selected number. (If the receiving-controller is dual-loop type, it operates using the target setpoints of the respective loops.)

*: Program pattern-2 generator (PT2.G) is a parameter provided only for UP750/UP550.



NOTE

The combination of Master and Slave (Loop-1 or Loop-2 mode) will result in a coordinated operation error.

The combination of Master (2-loop mode) and Slave will also result in a coordinated operation error.

● ON/OFF of the overshoot suppressing function “SUPER”

Note that if the SUPER function is disabled by the program pattern transmission from the sending-controller, the SUPER function of the receiving-controller is automatically turned OFF.

● Operation mode (RUN/STOP) switching

● PID number switching

● Switching over to the zone PID mode

In coordinated operation, the slave controller’s PID number depends on the setting of the master and slave controllers ‘ZON’ parameters. The table below shows the slave controller’s PID number selecting action.

Table 6.1 Selecting Action

Slave controller’s PID number selecting action Master controller’s setting	Slave ZON=0 (SP selection)	Slave ZON=1 (Zone PID, selects by PV)	Slave ZON=2 (Zone PID, selects by target setpoint) (UT551 only)	Slave ZON=3 (PID number selection) (UT551 only)
Master ZON=0 (SPselection)	Operates by the same PID number as the master’s controller	Operates by the same PID number as the master’s controller	Operates by the same PID number as the master’s controller	Operates by the PID number selection of slave controller
Master ZON=1 (ZON PID, selects by PV)	Zone PID Operats by PV.	Zone PID Operats by PV.	Zone PID Operates by target setpoint	Operates by the PID number selection of slave controller
Master (UT551only) ZON=2 (ZON PID, selects by target setpoint)	Zone PID Operats by PV.	Zone PID Operats by PV.	Zone PID Operates by target setpoint	Operates by the PID number selection of slave controller
Master (UT551only) ZON=3 (PID number selection)	Operates by the same PID number as the master’s controller	Operates by the same PID number as the master’s controller	Operates by the same PID number as the master’s controller	Operates by the PID number selection of slave controller



NOTE

The UT750/UP750, UT550/UT520, UT551, and UP550 display data in 5 digits. Data that is read/written via communication also consists of 5 digits. However, if you do not need to use 5-digit data for communication, set the data display digits of the controller to no more than 4 digits.

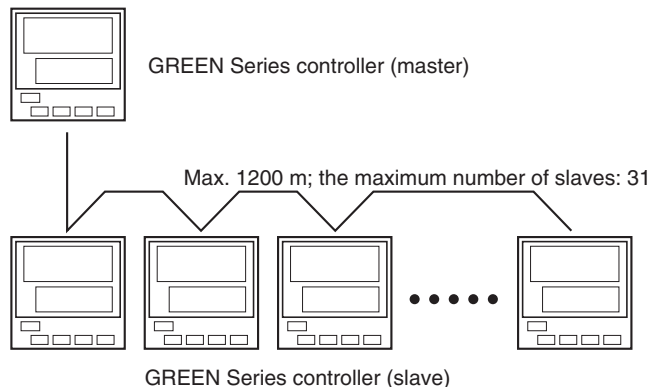

Figure 6.1 Connection of Coordinated Operation

6.2 Starting Coordinated Operation

After the wiring and setup of communication parameters have been completed, turn off the power once and turn it on again.

● Switchover of coordinated operation

(1) For UT750/UT550/UT520/UT551/UT450/UT420

Set all the slave controllers to remote mode.

Slave controllers do not operate in coordination when they are in local mode. (Each slave controller operates independently in local mode.)

(2) For UT350/UT320/UT351/UT321

Set the operating parameter SP No. of the slave controller to "0." Otherwise, coordinated operation will be disabled with that slave controller.

● Switchover of operation mode (RUN/STOP)

Switching over the master controller's operation mode also switches the operation mode of the slave controllers accordingly.

When a UT controller is the master, the operation mode (RUN/STOP) of slave UT controllers will be the same as the master's.

When a UP controller is the master, the operation mode (RUN/STOP) of slave UT controllers will be as shown below.

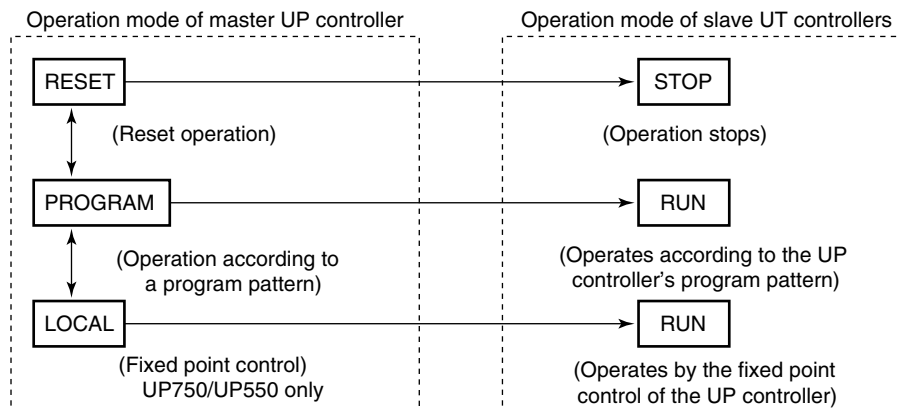

NOTE

If the operation mode of the slave UT controller is under the control of an external contact input, the operation mode cannot be switched by coordinated operation because the control by the external contact input takes priority.

In coordinated operation, slave controller's "target setpoint ramp-rate setting" is disabled.

Blank Page

7. Contact I/O Expansion

7.1 Overview

To UT750 and UP750, you can connect up to 2 units of digital I/O expansion modules of Yokogawa μ FA20 via μ -Bus. Connecting I/O expansion modules, UT750 and UP750 allows for a maximum of 32 points of additional contact inputs/outputs. (8 points of contact inputs and 8 points of contact outputs per module)

7.2 Setting Up Contact I/O Expansion

After wiring has been completed, set the station number (ST No.) on the μ FA20 expansion module.

● Setting the station number (ST No.) on the μ FA20 expansion module

For details, see the hardware manual of μ FA20 small programmable logic controller (IM 34M5F01-01E).

Set the station number with the rotary switch on the module. When connecting one module, set to "1." When connecting two modules, set the first module to "1" and the second module to "2."

Table 7.1 Station Number and I/O relays

ST No.	Input relays available	Output relays available
1	0101 to 0108	0151 to 0158
2	0201 to 0208	0251 to 0258



NOTE

The correspondence between the relay numbers of the I/O relays and the added 8 points is shown in Table 7.1.

Set the output reset/hold switch of the expansion module to OFF (the setting at factory shipment).

Table 7.2 Correspondence between Contact Terminals of the Expansion Module and Contact Input/Output Registration Parameters of GREEN Series

● Expansion module 1

Contact output terminal of expansion module	Contact output registration parameter (D register number)
OUTPUT51	R151(D1543)
OUTPUT52	R152(D1544)
OUTPUT53	R153(D1545)
OUTPUT54	R154(D1546)
OUTPUT55	R155(D1547)
OUTPUT56	R156(D1548)
OUTPUT57	R157(D1549)
OUTPUT58	R158(D1550)

● Expansion module 2

Contact output terminal of expansion module	Contact output registration parameter (D register number)
OUTPUT51	R251(D1551)
OUTPUT52	R252(D1552)
OUTPUT53	R253(D1553)
OUTPUT54	R254(D1554)
OUTPUT55	R255(D1555)
OUTPUT56	R256(D1556)
OUTPUT57	R257(D1557)
OUTPUT58	R258(D1558)

● Expansion module 1

Contact input terminal of expansion module	Contact input registration parameter (I relay number)
INPUT1	RDI101(I0177)
INPUT2	RDI102(I0178)
INPUT3	RDI103(I0179)
INPUT4	RDI104(I0180)
INPUT5	RDI105(I0181)
INPUT6	RDI106(I0182)
INPUT7	RDI107(I0183)
INPUT8	RDI108(I0184)

● Expansion module 2

Contact input terminal of expansion module	Contact input registration parameter (I relay number)
INPUT1	RDI201(I0185)
INPUT2	RDI202(I0186)
INPUT3	RDI203(I0187)
INPUT4	RDI204(I0188)
INPUT5	RDI205(I0189)
INPUT6	RDI206(I0190)
INPUT7	RDI207(I0191)
INPUT8	RDI208(I0192)

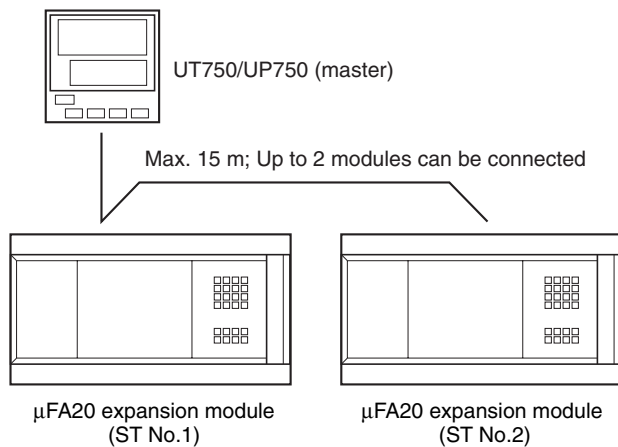

Figure 7.1 Connection of Contact I/O Expansion

Revision Information

- Manual Title : GREEN Series Communication Functions
- Manual No. : IM 05G01B02-01E

1st Edition/June 2000

Newly published.

2nd Edition/Jun 2003

Error corrections.

3rd Edition/Jul 2004

Product transfer to Yokogawa Electric Corporation.

4th Edition/Sep 2004

Error corrections.

5th Edition/Jan 2005

Addition of UT551.

6th Edition/May 2006

Addition of explanation in the figure.

Written by Yokogawa Electric Corporation

Published by Yokogawa Electric Corporation
2-9-32 Nakacho, Musashino-shi, Tokyo 180-8750, JAPAN

Blank Page

YOKOGAWA

Yokogawa Electric Corporation

YOKOGAWA ELECTRIC CORPORATION

Network Solutions Business Division

2-9-32, Nakacho, Musashino-shi, Tokyo, 180-8750 JAPAN

Phone: +81-422-52-7179 Facsimile: +81-422-52-6793

Sales Branch Offices

Tokyo, Nagoya, Osaka, Hiroshima, Fukuoka

YOKOGAWA CORPORATION OF AMERICA

Headquarters

2 Dart Road, Newnan, GA. 30265-1094 U.S.A.

Phone: +1-770-253-7000 Facsimile: +1-770-251-0928

Sales Branch Offices / Texas, Chicago, Detroit, San Jose

YOKOGAWA EUROPE B. V.

Headquarters

Databankweg 20, 3821 AL Amersfoort THE NETHERLANDS

Phone: +31-334-64-1611 Facsimile: +31-334-64-1610

Sales Branch Offices / Houten (The Netherlands), Wien (Austria), Zaventem (Belgium), Ratingen (Germany), Madrid (Spain), Bratislava (Slovakia), Runcorn (United Kingdom), Milano (Italy), Vélizy Villacoublay (France), Johannesburg (Republic of South Africa)

YOKOGAWA AMERICA DO SUL S.A.

Headquarters & Plant

Praca Acapulco, 31-Santo Amaro, Sao Paulo/SP, BRAZIL CEP-04675-190

Phone: +55-11-5681-2400 Facsimile: +55-11-5681-4434

YOKOGAWA ENGINEERING ASIA PTE. LTD.

Head office

5 Bedok South Road, Singapore 469270 SINGAPORE

Phone: +65-6241-9933 Facsimile: +65-6241-2606

YOKOGAWA ELECTRIC KOREA CO., LTD.

Seoul Sales office

395-70, Shindaebang-dong, Dongjak-gu, Seoul, 156-010, KOREA

Phone: +82-2-3284-3000 Facsimile: +82-2-3284-3019

YOKOGAWA TAIWAN CORPORATION

Head office

17F, No.39, Sec. 1, Chung Hwa Road Taipei, 100 TAIWAN

Phone: +886-2-2314-9166 Facsimile: +886-2-2314-9918

YOKOGAWA AUSTRALIA PTY. LTD.

Head office

CentreCourt D1, 25-27 Paul Street North, North Ryde, N. S. W. 2113, AUSTRALIA

Phone: +61-2-9805-0699 Facsimile: +61-2-9888-1844

YOKOGAWA INDIA LTD.

Head office

40/4 Lavelle Road, Bangalore, 560 001, INDIA

Phone: +91-80-227-1513 Facsimile: +91-80-227-4270

LTD. YOKOGAWA ELECTRIC

Grokholskiy per. 13, Build. 2, 4th Floor, 129010, Moscow, RUSSIA FEDERATION

Phone: +7-095-737-7868 Facsimile: +7-095-737-7869
